Electronic Disease Surveillance System (EDSS) Vendor Analysis

An Overview of the Selected EDSS Landscape for Public Health Agencies

April 2013 (revised August 2013)

Notice to Readers

The points below state the intentions of the Electronic Disease Surveillance System (EDSS) Vendor Analysis Report and also describe what the analysis report is and is not.

- This analysis report was conducted February 2013 through April 2013; it provides point-in-time information about the software vendors and the software capabilities. Software and technology are ever-evolving and may change over time. Consumers should take into account the time in which this analysis was conducted when evaluating the software vendors.
- It is not the intent of the Public Health Informatics Institute (PHII) to explicitly endorse one software vendor or product over another. The Electronic Disease Surveillance System (EDSS) Vendor Analysis Report provides an independent non-biased analysis. This analysis does not include software vendor recommendations, ranking, weighing or scoring.
- This analysis report was not validated by current users of the software. The report content (as well as the ratings of the software requirements in *Appendix A*) is solely based on PHII's analysis and interpretation of the software vendor's interviews and system demonstrations. It is highly recommended that consumers reach out to other public health agencies that have implemented an EDSS system by the vendor of interest.
- Cost factors were intentionally omitted from this analysis report due to significant variation in implementation needs, customer configurations and customizations requirements. Listing costs would not have depicted an accurate representation of the software for an individual consumer. However, some aspects of software acquisition and licensing are included in the report, such as: if the software is open-source; offered at no cost; how licenses are sold (per-intent or not per-intent); license limitations and subscription information.
- The report does not include an analysis of vendor stability. However, it does provide the vendor's years of existence.
- The analysis report leveraged a combination of previously defined surveillance system requirements defined by a workgroup of public health practitioners and state health department surveillance system requirement reports. The EDSS requirements used in this analysis may only represent 85-95% of the requirements of an Electronic Disease Surveillance System or of what may be important to an individual consumer. We encourage all consumers to rigorously define their individual surveillance system needs, then using nationally defined requirements as a start (see www.phii.org) and evaluate the requirements and vendors that meet those requirements.
- Each vendor received a copy of the analysis report and their requirement ratings prior to the publishing of the final report for external review.

Table of Contents

| | |
|---|----|
| Acknowledgements | 1 |
| Acronyms | 3 |
| Background & Purpose | 4 |
| How to Conduct Your Own Analysis | 5 |
| Analysis Approach | 6 |
| Vendor Landscape | 8 |
| Vendor Analyses | 9 |
| Comprehensive EDSS | |
| Atlas (Worldcare) | 9 |
| Collaborative Software Initiative (TriSano) | 12 |
| Consilience Software (MAVEN) | 15 |
| Specialized EDSS | |
| CDC (National Electronic Disease Surveillance System BASE SYSTEM – NBS) | 18 |
| STC (Sentinel) | 21 |
| Niche EDSS | |
| Emergint/CACI Intl. (HealthSIS) | 24 |
| EpiAnywhere LLC (EpiAnywhere) | 26 |
| This Analysis: A Platform to Launch a Vendor Selection | 28 |
| Appendix A: Requirement Comparability Matrix | 29 |
| Reportable Conditions Surveillance | 29 |
| General System Requirements | 42 |
| Technical Design | 45 |
| Data Exchange and Integration | 48 |
| Data Analysis, Visualization and Reporting | 50 |
| Appendix B: Glossary | 53 |
| Appendix C: CSTE List of Nationally Notifiable Conditions 8/1/2012 | 55 |
| Appendix D: Information Gathering Process | 56 |
| Appendix E: Interview Guide | 58 |
| Appendix F: Demonstration Script | 63 |
| Appendix G: RFP Template | 65 |

Acknowledgements

The Public Health Informatics Institute would like to thank the Centers for Disease Control and Prevention, specifically the Public Health Surveillance and Informatics Program Office and the Division of Notifiable Diseases and Healthcare Information for funding this initiative.

Special thanks to the Robert Wood Johnson Foundation for their generous funding of the “Redesigning Public Health Surveillance in an eHealth World” project report, published in June of 2012, and to the workgroup participants whose work led up to that report. The surveillance system requirements defined during the collaborative workgroup meetings served as the primary/core Electronic Disease Surveillance System requirements used to analyze each of the vendor solutions in this analysis.

Finally, we’d like to thank the following vendor contacts for their participation and willingness to provide us with information in a timely and comprehensive fashion:



Mark Maristoca, MBA
Vice President of Global Business
Development



Michael Wodajo, PMP
IT Project Manager



Stuart Cohen
Chief Executive Officer
Collaborative Software Initiative



Joy Alamgir
Founder and Executive Vice President



Timothy W. Ellis, M.S.
System Architect, Senior Principal/Software
Engineering Manager



Joe Kabel, Ph. D.
President, Looking Glass Analytics



Deborah Allwes
Director of Public Health/Senior Public Health
Advisor

The Public Health Informatics Institute (a program of the Task Force for Global Health) works with public health professionals and their stakeholders on projects centered around requirements development, practice support and informatics training. Our mission is to improve health outcomes worldwide by transforming health practitioners' ability to apply information effectively.

The Public Health Informatics Institute welcomes comments on this document and related issues. Please send all correspondence via email or phone using the contact information listed at the Public Health Informatics Institute web site (www.phii.org).

We encourage further *non-commercial* distribution of this report, but all uses in any form, in any quantity, or by any means—electronic, mechanical, photocopying, recording, or otherwise—must include the following attribution on all copies: “From *Electronic Disease Surveillance System (EDSS) Vendor Analysis*, Copyright 2013 by Public Health Informatics Institute. All rights reserved.” No other copyright, byline, or appearance of mutual ownership may appear on the copyrighted materials. The Institute’s copyrighted material cannot be altered. Under no circumstances can material be distributed for commercial use without specific written permission. For information on permissions, please contact us: drobic@phii.org.

Suggested citation

Public Health Informatics Institute. (2013). *Electronic Disease Surveillance System (EDSS) Vendor Analysis*. Decatur, GA: Public Health Informatics Institute

Published by

Public Health Informatics Institute
325 Swanton Way
Decatur, GA 30030

Copyright © 2013 by the Public Health Informatics Institute
All rights reserved.

Acronyms Used in this Report

API – Application Programming Interface

CRDM – Collaborative Requirements Development Methodology

CSV – Comma Separated Values

EDSS – Electronic Disease Surveillance System

EFC – Electronic Filing Cabinet

EHR – Electronic Health Record

ELR – Electronic Lab Record

HAN – Health Alert Network

HIPAA – Health Insurance Portability and Accountability Act

HL7 – Health Level Seven

LOINC – Logical Observation Identifiers, Names and Codes

OCR – Optical Character Recognition

PHCR – Public Health Case Report

PHINMS – Public Health Information Network Messaging System

SAS – Statistical Analysis System

SNOMED – Systematized Nomenclature of Medicine Clinical Terms

SOA – Services Oriented Architecture

SSRS – SQL Server Reporting Services

RFP – Request for Proposal

XML – Extensible Markup Language

Background

The Public Health Informatics Institute (the Institute) and the Centers for Disease Control and Prevention (CDC) have worked collaboratively to enhance the capabilities of the public health system since April 2008. This partnership is a part of the Cooperative Agreement, to *Strengthen and Improve the Nation's Public Health Capacity through National, Non-Profit, Professional Public Health Organizations to Increase Health Protection and Health Equity*. Through the Cooperative Agreement, CDC seeks to address three major health goals:

- Improve public health system performance of the essential services and the needed infrastructure.
- Assure that public health as a system of collaborating entities can meet the challenges of significant threats to health through preparedness.
- Improve the public health system's ability to manage health information.

The Division of Notifiable Disease and Healthcare Information (DNDHI) engaged the Institute to conduct an analysis (summarization of system capabilities and core competencies) of eight selected commercial off-the-shelf (COTS) and privately developed Electronic Disease Surveillance System (EDSS) vendors, and to distribute the findings to public health organizations. *(Seven of the eight selected vendors were analyzed; PRISM, from the Florida Department of Health, was unable to participate in the analysis.)*

Between October 2011 and March 2012, the Institute applied its Collaborative Requirements Development Methodology (CRDM)[™] to facilitate three meetings of a workgroup made up of 10 public health surveillance practitioners from different states and locales. Through these sessions, the workgroup collaboratively defined and developed functional requirements for an EDSS. The requirements developed in the workgroup were then used as the basis for performing the analysis of the selected EDSS vendors.

Purpose

The purpose of this analysis is to help state and local health departments explore the potential of available surveillance systems to meet their needs, framing the landscape of the EDSS world so that they can make informed surveillance IT decisions. The analysis represents a point-in-time snapshot of the functionality of these systems.

While this analysis does not constitute a vendor selection or recommendation, the analysis provides public health agencies a platform to inform their own selection processes, offering:

- Insight into the EDSS landscape, using the selected representative systems
- A framework to assist public health agencies in understanding their surveillance IT requirements
- Templates and information to help with analysis of vendors to being considered

How to Conduct Your Own Analysis

Public health agencies can conduct their own analyses by following the general steps depicted below:

Figure 1 - Analysis Steps

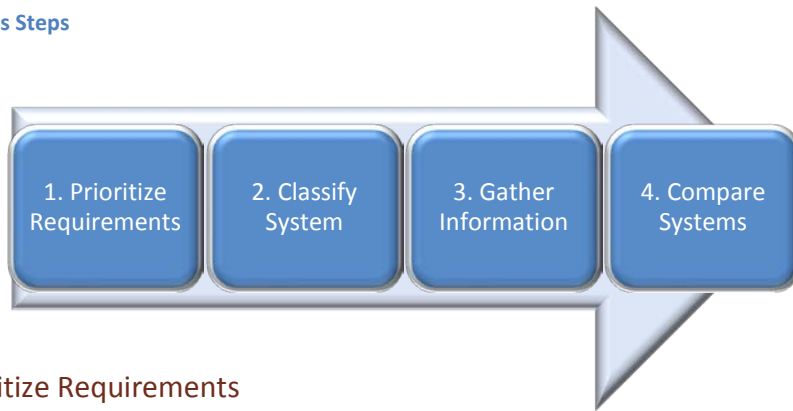

Step 1: Prioritize Requirements

- Gather the perspectives of public health users to determine which requirements listed in *Appendix A, Requirements Comparability Matrix* are important to your organization.
- Rank the importance of the requirements.

Step 2: Classify System

- Use the prioritized requirements to help determine what type of EDSS is required by the agency, and identify systems that fit that classification. Below are the criteria used to classify each EDSS for purposes of this analysis:

Comprehensive EDSS – Provides support for *all* of the core functions of Disease Surveillance for Reportable Conditions: Condition Reporting, Event Identification and Validation, Case Investigation, Contact Tracing, Case/Contact-Specific Intervention, and Event/Outbreak Management.

Specialized EDSS – Provides support for *a targeted subset* of the core functions of Disease Surveillance for Reportable Conditions. The functions supported by each system vary, but all have at least one core disease surveillance function that (by design) is not supported.

Niche EDSS – Serves a specific purpose in helping public health agencies gather and utilize data. Niche systems concentrate on only one or two of the core functions of Disease Surveillance for Reportable Conditions. Which functions are supported varies from system to system.

Step 3: Gather Information

- Utilize the Information Gathering Process from this analysis to get relevant information on the systems that align with agency needs.
- Use the templates in Appendix G to help frame a Request for Proposal (RFP).

Step 4: Compare Systems

- Compare the systems based on their ability to meet the prioritized requirements.

Analysis Approach

A requirements category framework was developed to aid in logically defining requirements for an integrated system for Electronic Disease Surveillance for Reportable Conditions. Note: The classifications discussed in the vendor landscape and individual vendor analyses are based strictly on the core functions of Reportable Conditions Surveillance, shown in the first box in Table 1, below.

The requirements used for this vendor analysis were gathered from previous projects funded by CDC and Robert Wood Johnson Foundation (see references, below).¹

Table 1 - Requirements Category Framework

| EDSS Requirement Categories |
|--|
| Support for Reportable Conditions Surveillance Core Functions: <ul style="list-style-type: none"> ▪ Condition Reporting ▪ Event Identification and Validation ▪ Case Investigation ▪ Contact Tracing ▪ Case/Contact Specific Intervention ▪ Event/ Outbreak Management ▪ Public Health Alerts |
| General System Requirements <ul style="list-style-type: none"> ▪ System Support ▪ Functionality ▪ System Administration ▪ Data Capture |
| Technical Design <ul style="list-style-type: none"> ▪ Technical Design and Architecture ▪ Development/Programming Languages ▪ Platforms ▪ Security/Privacy ▪ User Interface |
| Data Exchange and Integration |
| Data Analysis, Visualization and Reporting |

¹ Redesigning Public Health Surveillance in an eHealth World, *PHII*

A Market Analysis for Public Health Integrated Systems: San Francisco Department of Public Health, *NCHSTP Informatics*
Nevada State Wide Disease Surveillance Gap Analysis, *Kriseman, Labus, Foxen, Bonnet, Larsen, Rowley, Middaugh*

Each section of the framework encompasses a number of requirements – See Appendix A. For each requirement, a specific symbol, as defined by the table below, is used to denote how well the system fulfills the requirement. This is not meant to be a ranking or scoring to compare systems, but rather an indicator of the system’s ability to fulfill the requirement.

Table 2 - Symbol Definition

| Symbol | Definition |
|-------------------------------|---|
| Fully Meets Requirement ● | The assessors have determined that the system satisfactorily meets all parts of the requirement. |
| Partially Meets Requirement ◐ | The assessors have determined that the system meets some or most of the requirement, but does not “fully meet” the requirement. |
| Does Not Meet Requirement ○ | The assessors have determined that the system does not meet the requirement, in that (a) the requirement is intentionally not supported, or (b) the requirement is supported, but not satisfactorily. |

The information to complete the requirements matrix was collected using the Information Gathering Process flow, which is located in Appendix D. The three key interactions with the vendor were:

Figure 2 - Vendor Interactions



Vendor Landscape

In August of 2007, the Council of State and Territorial Epidemiologists (CSTE) conducted an assessment of EDSS implementations in all 50 states. What they found were systems that varied widely and were in various stages of implementation. With each jurisdiction creating its own set of requirements, the market had spawned disparate versions of EDSS as software vendors tried to meet those needs. Many states had created their own systems, or used commercial systems which were highly customized. With the high levels of customization and the need for so many more technical specialists, public health agencies – already experiencing funding challenges – faced high costs as the marketplace moved towards the concept of interoperability (the seamless integration of systems in order to share information). This dynamic has continued to shape the landscape for EDSS, with disparate software systems designed to meet different needs.²

For this analysis, eight vendors were selected as representative of the larger market as a whole, of which seven were analyzed. These include open source, government funded, and commercial software, and systems with varying levels of functionality for the core EDSS requirements. As the vendors were interviewed and information was gathered, we developed the classifications (Comprehensive, Specialized, or Niche EDSS) defined on page 5 to help public health agencies understand the scope of each system's capabilities and enable them to identify the type of system that best aligns with their priority requirements.

² Status of State Electronic Disease Surveillance Systems — United States, 2007 L Dwyer, MPH, KL Foster, MA, T Safranek, MDDisclosures Morbidity & Mortality Weekly Report. 2009;58(29):804-807.

Vendor Analyses

Each vendor analysis includes a profile of the system, system highlights, a synopsis, and a detailed analysis of the system in terms of support for the applicable core functions of Reportable Conditions Surveillance. Analyses of the seven vendors are presented alphabetically, grouped by classification. This arrangement does not represent any kind of ranking.

Comprehensive Electronic Disease Surveillance Systems

Atlas (WorldCare)

Comprehensive: WorldCare provides robust support for all of the Reportable Conditions Surveillance functions.

Highlights:

- Highly customizable/configurable by the end users
- Designed with input from former Public Health officials
- Focus of the system is at the local level
- User Defined Forms for creating custom forms using Microsoft Visio
- An electronic filing cabinet for any file type or image

Synopsis of Analysis

As a comprehensive EDSS, WorldCare handles all aspects of reportable conditions surveillance. From condition reporting, where the system can receive information via ELR or manual entry, to case investigation and outbreak management, the system consistently provides the public health user with an ability to gather relevant data across multiple areas of surveillance. The system is set up to be very user friendly and customizable.

| Profile | |
|-------------------------|--|
| System | WorldCare |
| Company | Atlas Public Health, a Division of Atlas Development Corporation |
| Address | Atlas Public Health 26679 West Agoura Road, Suite 200 Calabasas, CA 91302 |
| Size of Company | 251-500 |
| Current Implementations | 3 states, 3 counties, 1 Canadian province |
| Years in existence | 9 |
| Main Contact Info | Mark Marostica, V.P. Global Business Development Office: (512) 697-9450 Email: MMarostica@atlasdev.com |



Detailed Analysis

Condition Identification and Reporting

The WorldCare system is configured to handle any disease or condition. WorldCare uses a “dictionary” of diseases and conditions, which is configurable at the end-user level. As such, the end user can add a new disease entry to the dictionary very quickly. WorldCare can receive lab reports via an Electronic Lab Report (ELR), or via manual entry. The ELR comes across as an HL7 formatted message, and the system prefers the standards of 2.3.1 and 2.5.1 for these messages. Once a report of a condition is received, the report is tagged, based on the configurable filter parameters which govern the system, and all necessary structures are created, based on the workflow assignments and protocols associated with that condition. In addition, the system alerts the users of any impending workflow steps that they must fulfill. This workflow will govern the movement of each record throughout the system, and includes audit trail functionality.

Event Identification and Validation

Once a condition report is received by the system, WorldCare’s algorithms and thresholds (which can be configured by the end user) work to identify trends and route the condition to the proper program area. In WorldCare, the “program area” is a specific single user. WorldCare uses both geographic and temporal information for threshold analysis, and once the condition report is brought into the system, it is put into the database for analysis and reporting.

Case Investigation

WorldCare has a very robust case management system, able to collect standard geographic data as well as more particular information around guardians and risk factors. The system uses standard case management functionality, as well as including the ability to use signoff definitions (or approvals) of the case in question and the ability to assign an investigator to the case. WorldCare can also track multiple locators and identifiers and de-duplicates both contacts and cases. Another function of the case management portion of the system is an Electronic Filing Cabinet (EFC). The EFC allows the user to append multiple images or attachments of any file type. These can include PDFs, Excel files, etc., and works for multiple ELRs, as well. The system is very flexible and allows multiple inputs of symptoms and auto-classification of the case.

Contact Tracing

WorldCare supports both contact-centric and case-centric views. With contact tracing, WorldCare is able to provide graphical representations of contacts, whether on a map or using their Sequel Server Reporting Services (SSRS). Contacts can be linked together via user-defined criteria and can also be directly linked to an index case. Follow-up interview status can be maintained for the contact, and is subject to the same workflow parameters. The user can create a case directly from a contact if they desire, and also can use the contact information to capture risk factor data and free-form notes. Once a list of contacts is created, they can be sorted based on user-defined criteria and also prioritized by level of importance (priorities set by the user).

Case/Contact Intervention

For Case/Contact Intervention, WorldCare provides a standard set of templates for intervention plans, which can be modified. A default intervention plan is recommended by the system, based on the configuration, and can be added to an existing case record. The case or contact is saved with the

intervention plan, and the entire process is under a workflow that allows for varying degrees of data access security. The system retains cases indefinitely, though it flags records as being resolved and only houses the data for historical reporting purposes.

Event/Outbreak Management

WorldCare's Event/Outbreak Management module provides the necessary data to help end users respond to situations in a timely manner. Cases and contacts can be associated with an outbreak, including the ability to import large numbers of contacts (as in the case of a stadium, etc.) from a spreadsheet. An outbreak plan template, much like an intervention plan, can be selected and then modified to fit the specific needs of the outbreak, according to the jurisdiction. The system tracks both confirmed and probable cases, as well as the status of all follow up interviews. For monitoring in real time, WorldCare has a separate module, known as Guardian. Atlas' clients have chosen not to integrate syndromic surveillance into the system. The system is capable of allowing the data to be directly interfaced, but no client has so far required this functionality. The data are housed in the repository for historical and reporting purposes. In addition, the system communicates with public alert networks to provide messaging and notification of outbreaks.

General System Functionality

The system uses a modern user interface that is very intuitive. Data are validated and de-duplicated upon entry (whether manual or electronic) and queued up for end-user workflows. WorldCare integrates with all types of public health systems and supports meaningful use, using HL7 messaging. It converts house lab codes into standard code sets, such as Logical Observation Identifiers, Names and Codes (LOINC) and Systematized Nomenclature of Medicine Clinical Terms (SNOMED). WorldCare uses standard components and hardware, and is using components which are likely to still be active in 5-10 years. 75 percent of the user base for WorldCare install the system themselves. This means that WorldCare can be run with little deployment configuration or customization. The system is accessed through a web browser, with Internet Explorer as the preferred browser. Although the system can be run as delivered, it is very flexible in allowing for any desired configuration or customization by the end users. Four maintenance releases are scheduled per year, on a quarterly basis. Each year, a full update is generated under the maintenance agreement.

WorldCare is sold on a user-license basis. The core system can also support the addition of Atlas Global Health modules such as Guardian Infection Prevention and iON Public Health Reporting Services. WorldCare has a yearly maintenance cost associated with it, and that cost is based on the size of the user population. In addition, Atlas can host the system for a "cloud-based" approach. They provide customer and technical support and users have a transparent view into their defect-tracking system.

Collaborative Software Initiative (TriSano)

Comprehensive: TriSano provides support for all of the Reportable Conditions Surveillance functions.

Highlights:

- Integrates with many public health systems for greater efficiency
- Provides support to both local and state public health agencies
- Annual subscription with no up-front license charge
- Data collecting is robust enough to meet the needs at local/state/federal levels

Synopsis of Analysis

TriSano successfully operates as a comprehensive EDSS. The system provides support for any number of diseases and conditions, and integrates easily with multiple systems for added efficiency. Information coming into the system is properly validated and audited, and is set up to move through workflows. Alerts and notifications tell users when activities need to be completed. Using Pentaho, a business intelligence and analytics tool, TriSano provides easy-to-use business analytics and reporting services. All types of required data can be collected on cases, contacts or events, and the data are linked. In addition, a yearly maintenance fee for TriSano covers both support and software maintenance.

Detailed Analysis

Condition Identification and Reporting

TriSano is able to support all reportable diseases. The system does not concentrate on specific diseases, as its Form Builder allows end users of the system to add new diseases. TriSano can receive ELRs in both HL7 2.3.1 or 2.5.1 formats. Alerts and notifications around these ELRs can be set up to notify the proper public health users that there is work in the queue. This first step in the workflow around the ELR allows the end user to create a new event, update an existing event, or discard the lab results altogether. In general, TriSano can support any HL7 message, but it is not recommended to allow TriSano to be the first system to receive ELR data, as not all lab data are meaningful to disease tracking. For this purpose, TriSano utilizes programs like Rhapsody or Mirth for the pre-processing. Once in the system, TriSano can manage Logical Observation Identifiers Names and Codes (LOINC) and Organisms for laboratory and clinical observations and tests.

| Profile | |
|-------------------------|--|
| System | TriSano |
| Company | Collaborative Software Initiative |
| Address | 1 SW Columbia Street, Suite 640 Portland, OR 97258 |
| Size of Company | 11-50 |
| Current Implementations | 2 states, 150+ counties and health districts |
| Years in existence | 6 |
| Main Contact Info | Stuart F. Cohen, Chief Executive Officer Office: (503) 295-7970 Email: stuart@csinitiative.com |

Event Identification and Validation

Part of the TriSano platform is a business intelligence and analytics tool called Pentaho, which is included with TriSano at no additional cost. Pentaho is responsible for much of the analytics and reporting functionality, and is the area where event trends are recognized. TriSano also includes Google Maps Premier for address lookup and verification, as well as geocoding and mapping. This allows the user to map all sorts of permutations of patients/contacts/outbreaks, all the way to the latitude/longitude of each address. Data sources are organized by jurisdictional areas, and can be grouped and dissected in many ways, including the ability to group by syndromes. Case routing occurs in the system, and can be triggered based on administrator-defined thresholds and priorities.

Case Investigation

All of the standard functions of a case (add, modify, save, close with added information) are standard in the system. Once a case is created, it can be assigned to an investigator and an audit record is logged. Cases can also be created from a contact record. End users are provided case templates, but they also have the ability to modify and create their own forms and questionnaires. Users can then exchange information with care providers, using forms that capture all types of data on the case: standard demographic information, legal responsibility, and any attachments the user deems necessary. The system then gives the user the ability to prioritize the cases, but does not automatically prioritize them. As a result of this ability, a user can override a priority based on new information, such as an evaluation. The system also provides end users with the ability to make links between contacts (such as relatives, etc.) by providing the analysis and data which the end users can then act on.

Contact Tracing

TriSano provides the ability to link one uniquely defined person to another to create contact webs and mappings. As mentioned previously, the visual representation of the maps is through a combination of Google Maps and Pentaho, both of which are a part of the TriSano platform. Using TriSano's contact tracing presents a contact-centric view of the data in the system, which includes additional data points like risk factors or facility contact information, and also provides the ability to add user-defined characteristics to the contact. Standard free-form text boxes for notes are present, and the system can manage the interview process through contact tracing. A contact is easily linked to an index case, and contact follow-up is prioritized through the intervention of an end user. The tracking in the system is very flexible and can accommodate like-identifiers, multiple lab reports for an individual case, multiple results for a sign or symptom, and the source of the exposure.

Case/Contact Intervention

TriSano allows the end user to create a pre-determined intervention for a given disease. Then, when an instance of the disease is created, the pre-defined intervention plan is suggested. This plan can be modified and saved, and attached to the case record for tracking and managing. Cases are never automatically closed, but must be manually closed with reason indicated. The system provides an administrative function for deletion of data, but it must be configured by each client based on their business needs.

Event/Outbreak Management

TriSano creates a unique record number for an event. The system communicates with other systems using a wide variety of output report formats. In addition, an interface into the system eliminates manual data entry. The goal with the data export is to allow epidemiologists and informaticians to get the data out of

TriSano and into their own analytical tools. Historical outbreak case definitions are kept in the system and can be uploaded in a batch format, as well. Outbreak plans can be generated, saved and edited, and a template library is available. Cases can be linked to an event, and TriSano tracks a number of outbreak-related data points: number of cases, both confirmed and probable, by geography or setting, temporal or spatial clusters, interview status and follow ups, to name just a few. The system does not monitor the data streams; the information has to be sent to the TriSano system, so it is not real-time. Also, a view from the data warehouse could provide the same information, not in real time. Using Pentaho, TriSano supports calculations of epidemiologic stats and activities like updating epidemiologic curves. TriSano supports all types of reporting of the data.

General System Functionality

TriSano uses a modern interface to allow its end users easy access to the information they need. It is set up to de-duplicate and validate the data as they come into the system, to maintain data integrity. TriSano integrates with a number of systems, through HL7 messaging, exporting and importing of a number of file types, and an Application Programming Interface (API), which allows for directly interfacing with the system. TriSano recommends messaging software like Rhapsody to pre-process messages as they come into the system, mainly as a way to filter out non-disease related information. When a system shares data with TriSano, the data are brought in based on an administratively scheduled time period. TriSano provides both an on-premise solution (where the public health agency houses both client and server systems) or as a “cloud” based solution, where TriSano hosts the instance for the public health agency.

TriSano is offered on an annual subscription basis, with no up-front license charge. Collaborative Software Initiative offers an Enterprise Support structure which gives users access to a Knowledge Base, professional documentation, installation and tuning advice, bug fixing and tracking, and service packs between releases, as well as support for globalization.

Consilience Software (MAVEN)

Comprehensive: MAVEN provides support for all of the Reportable Conditions Surveillance functions.

Highlights:

- Highly configurable system – end users can set parameters of the system during deployment, and customize once the system is live
- Flexibility for interfacing – supports HL7 messaging, XML, and custom interfaces
- Per Intent Basis Licensing agreement – no restrictions on number of users
- Cross-jurisdictional capabilities
- Yearly user group conferences to discuss system user needs

Synopsis of Analysis

As a comprehensive EDSS, MAVEN provides robust functionality in case management, event/outbreak management, contact

tracing, condition reporting, and case or contact investigation and intervention. MAVEN is highly configurable and designed to adapt to changing needs without costly source code changes. MAVEN successfully keeps a similar look and feel across program areas so that minimum training is required to use the system. In addition, MAVEN shows great flexibility in both its interfacing capabilities and in its jurisdictionally directed customization. MAVEN can work cross-jurisdictionally, which aids in gathering different sections of data. Finally, MAVEN wraps the collected data into dynamic reporting and graphics capabilities, and does much of the work behind the scenes using a variety of user-defined algorithms.

Detailed Analysis

Condition Identification and Reporting

MAVEN supports the collection of data on over 95 communicable diseases, and can support all reportable conditions. In addition, MAVEN provides an easy and intuitive method for the end user (with proper permissions) to create new diseases or conditions in a manner of minutes to hours (ex., H1N1).

The specifics of the configuration are tailored to the jurisdiction on deployment. For example, in New England, Lyme disease is prevalent, whereas in New York City, the focus is more on tuberculosis. When a condition enters the system (either manually or via electronic interface) the system reviews the data and automatically filters the disease specifics, then places it under the disease type best matched by the data, including profile information of the patient, lab reports, etc. This is done through the MAVEN De-Duplication Module. As conditions are received, automated workflows start sending alerts and notifications to the proper points of contact.

| Profile | |
|-------------------------|---|
| System | MAVEN |
| Company | Consilience Software |
| Address | 11149 Research Blvd., Suite 300 Austin, TX 78759 |
| Size of Company | 11-50 |
| Current Implementations | 9 states, 5 cities |
| Years in existence | 11 |
| Main Contact Info | Joy Alamgir, Executive Vice President Office: (512) 769-1889 Email: jalamgir@consiliencesoftware.com |

Event Identification and Validation

MAVEN uses a set of highly configurable built-in algorithms to identify events and event trends. These algorithms live in the outbreak management module of MAVEN. The user can utilize geographical or temporal data to identify events either automatically or manually. MAVEN collects data from many disparate systems and can shape and sort the data in a myriad of ways utilizing advanced search capabilities. MAVEN uses both workflow functionality and audit capabilities for event identification and validation.

Case Investigation

MAVEN provides a robust case investigation system. Cases can be received by the system via manual inputs, scanning, or Optical Character Recognition (OCR) parsing. Rules and tasks are set up around the case type, as per the configuration requirements. Attachments and other free-form notes can be added, and user-friendly editable case templates are saved in a template library. MAVEN supports case management elements around assigning to an investigator, and also allows the user to create a case directly from a contact record. The system facilitates follow-up communications with care providers. Trends and like-identifiers are tracked, using the de-duplication module.

Contact Tracing

MAVEN uses contact tracing as a very meaningful tool to help in the surveillance of diseases. Bi-directional links between contacts are established to visually represent clusters and possible outbreaks. These can be any person-to-person link. The system can prompt the user for possible links (ex., two users with the same address), but it does not automatically create the link, as that function is best left to human intervention. The data captured on the contact are robust and include risk factor data, contact information for the facility (for aggregation), and a free-form notes field for any additional information. The contact can be associated with an index case, which can then be used to help prioritize the contact follow-up.

Case/Contact Intervention

MAVEN supports the use of template plans to aid the user in carrying out the intervention. Plans are pre-defined and automatically selected based on the case, but can be tailored to the specific instance. Like most of the configuration, tailoring of the plan takes place at an administrator or supervisor level; general end-users cannot edit the plans. The intervention plan allows for workflow tasks, which send alerts and notifications to the users who have tasks or steps to perform. Cases are automatically closed using configured parameters and thresholds. However, data are not deleted from the system, so that they can be used for historical reporting.

Event/Outbreak Management

MAVEN utilizes their outbreak management module to facilitate the management of an event or an outbreak. MAVEN systematically trolls the data coming into the system to recognize patterns which may be interesting to an epidemiologist. In addition, known patterns can be manually added to the system. Once a possible event or outbreak is identified, surveys can be automatically sent to associated contacts. The communications are tracked, and follow-up can occur. Cases are linked to the outbreak, and a user now has a holistic view of the outbreak and a large toolkit of reporting options to show the information they want to highlight.

General System Functionality

MAVEN is “browser agnostic”, meaning that it can be run on any browser. MAVEN was constructed in a way that it is scalable both horizontally and vertically. The user interface was designed by Consilience based on studies of their user base. The look is consistent across modules. MAVEN is easily configurable by the end user. It allows end users to add new diseases in the system to accommodate emerging threats (ex., H1N1 outbreak). Once input, either manually or electronically, the data are validated both syntactically and semantically to ensure it is clean. Security is handled by roles and user groups, and all messages in and out are encrypted.

MAVEN is licensed on a “Per Intent” basis. This means that any number of users that fall under the “intent” can use the system. For example, the license could be for “Public Health Agency A” and any member of Public Health Agency A could then use the system. There is a yearly maintenance fee attached to MAVEN, and also a cost on deployment, based on the size and complexity of the configuration required. The core functions of MAVEN are not changed, so upgrading even a heavily-configured system is relatively easy. Consilience provides different levels of support. Tier 1 and 2 support levels handle activities like password resets and other common IT-related problems. Tier 3 support is for issues with greater functional impact, as well as any development required to fix a problem. Consilience also staffs 24/7 emergency support for “blocker” issues – those issues which prevent system use.

Specialized Electronic Disease Surveillance Systems

CDC (National Electronic Disease Surveillance System BASE SYSTEM - NBS)

As a *specialized* EDSS, NBS contains functionality in: Condition Identification and Reporting, Event Identification and Validation, Case Investigation, and Contact Tracing.

Highlights:

- Point of Time Demographics – Able to identify and track a contact’s reportable condition disease record over the course of the contact’s life
- Page Builder – Allows for customization as new message mapping guides are provided by the CDC
- Compliance with CDC notification standards
- Open source – freely available to the public
- NBS can integrate with other EDS systems and serves as a conduit to send reportable condition information to CDC

Synopsis of Analysis

NBS is classified as a specialized EDSS because of its focus as a case management system that provides easy interfacing and gathering of information required by the CDC. NBS is a solution geared toward state health agencies, and uses its various tools to gather information on conditions and cases, but does not provide any functionality around case/contact intervention or outbreak management. NBS is integrated with ELRs and Public Health Case Reports (PHCRs), and is flexible to receive new conditions or diseases.

Detailed Analysis

Condition Identification and Reporting

NBS collects data on 140 different conditions that are reportable to the CDC. In addition, NBS is able to gather information on non-reportable conditions. NBS does not collect information related to STDs/HIV, but this is currently under development. A condition form is based on the message mapping guide provided by the CDC, and can be created and edited by an administrator at the given instance. NBS sends

| Profile  | |
|---|--|
| System | NEDSS Base System (NBS) |
| Company | Center for Disease Control and Prevention |
| Address | Division of Notifiable Diseases and Healthcare Information centers for Disease Control and Prevention 1600 Clifton Rd. Mail stop E-91 Atlanta, GA 30333 USA |
| Size of Company | 251-500 |
| Current Implementations | 18 states, 1 city |
| Years in existence | 12 |
| Main Contact Info | Michael Wodajo, PMP IT Project Manager Office: (404) 498-6675 Cell: (678) 733-4692 Email: MWodajo@cdc.gov |

the collected information in the proper format to the CDC. NBS integrates with other EDSS and serves as a conduit to send reportable conditions information directly to CDC.

When a condition enters the system, either manually or via ELR, NBS identifies the condition and routes it to the appropriate program area. This automated routing is governed by the business rules set up for a given condition and program area (which are linked.) These jurisdictional rules can be configured or modified, as can the proper user notifications or alerts that occur when the condition enters the system. The system supports multiple lab formats, and flags the records when lab results have been received. In general, NBS captures all information necessary to report to CDC.

Event Identification and Validation

NBS receives lab messages via ELR in HL7 format. The transmission of these messages is handled by Public Health Information Network Messaging Service (PHINMS), which handles security and uniformity of messaging. In addition to normal workflows, the user can set up an algorithm which can start a case investigation on syndromic data alone. The event has a workflow around it, and using priority thresholds, the event can be classified as a case and routed to the proper program areas. Users define the priority for themselves, so they can easily recognize and be alerted to high priority items. All of this is done automatically once configured.

Once data are in the system, the users can run reports utilizing geographical and temporal data to identify events and recognize event trends. These reports are run from a selection of searchable data sources, as NBS keeps directories of these (such as ELRs, Public Health Case Reports - PHCRs, case investigations, etc.) by jurisdictional area. Complicated analysis and reporting is done by exporting the data from NBS and importing into a Statistical Analysis System (SAS).

Case Investigation

Case investigation is the core module of NBS. There are case templates to choose from, all based on the CDC's information requirements. These forms are editable so that an end user with proper security access can update the form to match changing parameters in the messaging guide, or to create brand new templates. A case can be accepted, rejected, or saved. Once the case is accepted or saved, it can be assigned to an investigator, and that investigator can also be changed. All transactional data are captured in an audit log. The case forms are robust, allowing the user to add attachments and free-form notes, and capturing standard demographic information as well as legal responsibility contact information. While no algorithm allows the system to perform a risk evaluation on the case, in general, workflows can be configured to remove conditions that are not urgent or require immediate attention. A case can be created directly from a contact, but the system does not automatically prompt the user to apply contact tracing. While managing the case, the system can track multiple instances of locators, like identifiers and multiple lab reports for each individual case, as well as the source of the exposure. The system employs Point of Time demographics so that even if certain identifying information changes on a contact, the history is maintained. For example, a person who gets chicken pox at the age of eight in Minnesota can be linked to the seventy-five year old who exhibits shingles in Florida later in life. The system will auto-classify a case and change that classification as more information comes into the system.

Contact Tracing

NBS only provides minimal functionality around contact tracing. Links are made between persons manually, and information, like risk factor data, is captured. Contacts are not sub-classified in any way, and so fall into a large pool of contacts. With the implementation of the STD modules, contact tracing will

be enhanced. The release, scheduled for November 2013, will allow for interview follow-up, graphical representation of contacts, and other standard contact tracing activities.

General System Functionality

NBS is, at its core, a case management system, with the ability to provide valuable data and reporting around those case functions. NBS interfaces with ELR and the Health Alert Network (HAN) and utilizes the current standards of HL7. Unlike other systems, NBS also allows the interfacing of parallel or subordinate jurisdictions, via messaging. Currently, NBS is not based on a Service Oriented Architecture (SOA), but it is moving in that direction. The intent is to provide greater flexibility in the offering once it is in the SOA model, as a SOA provides greater reliability and reduced hardware acquisition costs, and allows greater flexibility in development of new functionality.

NBS provides a variety of reporting and data collection capabilities. The user interface is a standard web form and is relatively easy to use. As previously mentioned, the system supports user roles and security based on parameters like program areas, jurisdictions, or other permissions. NBS is a single sign-on application, so password expiry rules are handled by the client's workstation. The system archives data, moving them from the operational database to the reporting database.

Although CDC owns the NBS system, they outsource the maintenance of the software to SAIC, Inc., who schedule one major and two minor releases per year. In addition, patches are sent out periodically, usually on a two-week turnaround. The system is rolled out as a standard configuration, which then can be customized on three levels: 1) A configuration file that sits locally on the system; 2) configuration by a system administrator (this person is trained by SAIC); 3) configuration by SAIC. SAIC supports NBS at the state level by providing higher-level support with problems that affect the system, etc. The state handles normal administration of the system. The NBS package consists of an instance of SAS, Rhapsody, and a relational database, as well as an End User License Agreement for using NBS.

This software is open source and freely available for public health agencies to utilize.

STC (Sentinel)

Sentinel is very close to a comprehensive EDSS, but it is classified as *specialized*, because, while it handles everything from condition reporting to event/outbreak management, the actual functionality behind event/outbreak management occurs in a separate module.

Highlights:

- Facilitates easy reporting to CDC
- Integrates with large number of systems using HL7 messaging
- Provides flexibility, in that all data within the system are exportable for use in third party analytic tools
- Maintains a user consortium where Sentinel users can exchange ideas and work on functionality

Synopsis of Analysis

Sentinel is a highly configurable system which has robust functionality in most aspects of disease surveillance. STC has created a product which helps public health agencies do their jobs, but without automating away the epidemiologist's interaction with cases/events/outbreaks. The system captures all the necessary data for useful reporting and tracking, and facilitates easy reporting to the CDC. The system integrates well with other systems and is user friendly and adaptable.

Detailed Analysis

Condition Identification and Reporting

Sentinel is a completely configurable system which can handle any disease that is added, from infectious diseases with mandatory reporting, to veterinary diseases. As such, Sentinel does not concentrate on any given type of disease or condition. The addition of a new disease is done at the administrator level, so it is a specific local end user who has the rights to make the change. The diseases are set up as part of a dictionary of diseases and are maintained in the system. Conditions come into the system via manual input or ELR. At this point they are now a case within the system. There are automatic workflows around each specific disease, so an alert is sent to notify a configured group of users that there is a pending ELR. Alerts can be set to notify based on a threshold being reached, as well. Since state requirements for laboratory testing differ, the system is flexible enough to support multiple laboratory tests per condition, and in multiple formats.

Event Identification and Validation

| Profile  | |
|---|--|
| System | Sentinel |
| Company | Scientific Technologies Corporation (STC) |
| Address | 4400 E. Broadway Blvd, Suite 705 Tucson, AZ 85711 |
| Size of Company | 11-50 |
| Current Implementations | 4 states |
| Years in existence | 25 |
| Main Contact Info | Deborah Allwes, Director of Public Health Senior Public Health Advisor Office: (520) 202-3333 Email: Deborah_Allwes@stchome.com |

Sentinel receives laboratory messages in standard HL7 formats. In addition, the system can take comma-separated value (CSV) files and import them into the system as ELRs. Formats and messaging are adjustable. While the system does not automatically determine trends or events, it does provide the data so that an epidemiologist can make the proper classification. This includes the ability to use both geographic and temporal data and algorithms to help identify events and trends. With the purchase of an additional module, Sentinel interacts with mapping software to show contact/case points. However, this does not allow the system to identify clusters. The system groups data from different sources but does not do any syndromic surveillance. Once an event is identified, it can be given a higher priority in the system. All of the activities with the event record are managed via a workflow and have full audit trail capabilities.

Case Investigation

Sentinel supports all of the basic requirements for cases. Users can accept, reject, save, and close a case, with specific permissions at each step. Standard demographic information is captured, as well as contact information for the legally responsible party for the contact in the case. The cases themselves come into the system via manual input or ELR messaging. The cases are based on CDC case investigation forms, so any new templates are created by STC for roll-out to all of their Sentinel systems. The goal is to streamline the process of getting the correct information to the CDC. The system does not automatically prioritize cases, nor does it let the user know that contact tracing needs to occur. Through the system, the user can track multiple instances of locators, like identifiers, multiple lab reports for an individual case, and the source of the exposure. In general, Sentinel does not auto-classify cases, etc., because end users have requested the ability to have an epidemiologist make those decisions.

Contact Tracing

Sentinel contains robust contact tracing functionality. In addition to standard demographic data on a contact, Sentinel also captures risk factor data and contact info for a facility for aggregate functions. The system displays the contacts in a map and can show the manually defined links between contacts. The system allows importing of large contact lists, and can provide the ability to manage interview statuses (currently does this for tuberculosis, but not for any other diseases). While there is no way to systematically prioritize contact follow-up, the contacts are placed in a queue for additional information. In addition, contacts are linked to an index case, and inherit the information from that case.

Case/Contact Intervention

Sentinel displays a set of pre-defined intervention plans, dependent on the disease or condition. To change these, or select a new one, they must first be exported, then changed, then re-imported. They are handled as attachments and are not integrated into the system. These intervention records follow the same rule of workflow and audit trail as the cases and contacts.

Event/Outbreak Management

As a base system, Sentinel does a certain amount of event/outbreak management, but STC also sells a more robust version of this functionality in a module called the Outbreak Management System (OMS). If a Sentinel system has the OMS module installed, then it can add questionnaires, track historical outbreaks, and allow the user to create questionnaires. OMS is uni-directional to Sentinel, so work done in OMS is transported (via interface) into the core Sentinel system. OMS cannot be directly accessed from Sentinel. The system provides alerts and notifications on outbreaks, and can capture feedback on those communications for honing messages in the future. Cases are linked to the outbreak in Sentinel, and

Sentinel allows for many other tracking capabilities. Monitoring of data streams is considered to be part of syndromic surveillance, and as a result is a totally different system from Sentinel. Metrics can be created, used, and updated, and while thresholds can be changed by the end user, importing of formulas must be done by STC. STC allows for all types of reporting of the data, and focuses its attention on providing easy methods for the users to transmit the mandatory reporting pieces to the CDC.

General System Functionality

Sentinel integrates with all types of systems, including ELRs, Labs, State Immunization Registries, and EHRs. The system supports CDC mandates for messaging, and uses HL7 2.5.1 for most of the messaging. Sentinel uses normal data security measures and validates data as they come into the system. In addition to standard encryption processes, Sentinel implements user roles which limit access to both data and functionality within the system. The interface is easy to use and has recently been revamped as the result of discussions and workshops with end users.

STC is looking at cloud based options for Sentinel as well as open source or subscription methods, but is currently a browser based system with a small IT footprint at the site. Sentinel is updated three times a year, and STC provides bug fixes and patches as needed. The software is provided on an end user licensing agreement, and the maintenance cost is a percentage of the licensing, based on number of users.

Niche Electronic Disease Surveillance Systems

Emergint/CACI Intl. (HealthSIS)

Niche: HealthSIS has a particular focus on routing data to the local public health agencies from the hospital system, to facilitate public health surveillance at the local level, as well as to aggregate data to a statewide NBS system.

Highlights:

- Provides real-time surveillance and disease reporting from hospitals to public health departments
- Streamlines and automates much of the reporting process, which reduces manual processes
- Data engine allows for flexible notifications

Synopsis of Analysis

HealthSIS serves the purpose of providing for data gathering at the local public health level, for agencies which did not have access to the information in a timely manner. Electronic laboratory reports are captured directly from the HL7 data stream at the hospital and delivered directly to the public health installation or continued transmittal up the chain to the CDC when reportable (configurable) criteria are met. HealthSIS relies on NBS to be the case management system, and so does not support contact tracing or event/outbreak management. HealthSIS succeeds in providing real-time data to the public health agencies from the hospitals through the use of an interface engine. The interface engine extracts the necessary data from the hospital systems without manual intervention. The collected data are kept in the repository for reporting and analytics.

Detailed Analysis

Condition Identification and Reporting

HealthSIS has no current limitation on the number of diseases or conditions that they can support. In practice, their implemented system supports 19 diseases. In order to add additional diseases, one of two methods is utilized: it can be done at the user/administrator level for a routine disease, where only configuring a workflow for reporting would occur; or, if the disease requires additional forms (such as a newly reportable disease for which the CDC has provided a messaging guide), then the development would be done by Emergint Technologies /CACI Intl..

| Profile  | |
|---|---|
| System | Health Surveillance Information System (HealthSIS) |
| Company | Emergint Technologies/CACI Intl. |
| Address | 455 South 4th Street, Suite 1250 Louisville, KY 40202 |
| Size of Company | 201-500 |
| Current Implementations | 1 State, 8 Counties, 25 Local |
| Years in existence | 14 |
| Main Contact Info | Timothy Ellis Office: (866) 681-0149 x6209 Email: tellis@caci.com |

As a public health user, upon entering the system, you are greeted with a portal through which to begin your surveillance. As a condition comes into the system, the pre-defined configuration creates a condition-specific workflow. In this way, if a certain disease or condition has a different routing structure, then a new workflow is configured for that condition. Within the portal, users can configure the data-filtering criteria according to their security roles. When a condition is in the system, proper alerts and notifications go out to the interested parties within the system. This is automated as part of the ingestion workflow. All of these communications are within the system. The system can support multiple lab testing requirements, and this is done by configuration.

Event Identification and Validation

Messages come into the system via the HL7 lab format. HealthSIS takes the HL7 messages and generates XML messages for easy interfacing to other systems. Once the data reside in the public health database, various reporting functions can be applied. The user can use both geographic and temporal data to perform analytics or determine data trends. In addition, this information can be displayed in Google Earth or Google Maps. The system does not recognize event trends, but the data can be analyzed and dissected by syndrome or some other pre-defined criteria. Program areas do not exist in the system per se, as conditions live in queues until they are triaged. All alerts have equal priority, with no delineation.

Case Investigation

HealthSIS involvement in case investigation is strictly in passing information up to the state level (NBS) in order for that system's case management to function. A case is flagged or created, and then passed along for the actual management to occur. These functions are all followed via audit trail, which includes entries for edits and creation as well as views and searches. In summary, HealthSIS acts as a repository of this information and passes it along.

General System Functionality

HealthSIS is a repository for all the public health information that can be gathered from the hospitals. HealthSIS provides some solid reporting on the data in its system, including Epidemiologic curves, GIS and other customized or ad-hoc reports. HealthSIS uses information currently found in the hospital environment to populate the local surveillance. The system is 508 compliant, even though it is not required to be. The user interface is designed around entry forms that match the forms required by the state system.

HealthSIS is developed in an open-source format and will be supportable in the future. Configuration of HealthSIS is done by using configuration files locally on the servers. Emergint/CACI Intl. prefers the use of IE6 or later for the browser, but is moving towards being browser-agnostic. Currently, Emergint/CACI Intl. issues quarterly releases of both bug fixes and updates. They are moving toward the cloud in the near future. The system uses a 12-month operational data store, and after that the data are archived. Data are not only secure, but can be de-identified and versioned. Standard form level data validations are apparent as well. The total cost of the system is a maintenance fee. This maintenance allows for monitoring and updates, as well as agreed upon improvements.

EpiAnywhere LLC (EpiAnywhere)

Niche: EpiAnywhere is primarily used as a data entry system for public health users in the field, with limited infrastructure or access to technology.

Highlights:

- Provides easy data entry for required forms
- Meets form standards for both WHO and CDC
- Cloud based system hosted by vendor
- Streamlined transfer of form data to the CDC
- Supports multiple languages

Synopsis of Analysis

EpiAnywhere is a system created to collect surveillance data. The system is tailored to public health users, to maximize their efficiency in filling out required forms both for the CDC and for the WHO. The system

is highly beneficial to smaller public health agencies with limited IT budgets and resources. The system helps in getting better, more accurate information to the CDC and WHO, and provides the ability to analyze reported data at the local level.

Detailed Analysis

Condition Identification and Reporting

EpiAnywhere currently supports gathering data on tuberculosis, several STDs, and leprosy, and is working on models for Hepatitis and HIV/AIDS. The system itself does not concentrate on any given disease, but a new module must be created by EpiAnywhere when adding a new disease. EpiAnywhere can report to both the CDC and World Health Organization. Based on user input, EpiAnywhere creates the specific forms that a given jurisdiction needs to properly capture all data. Once a condition is input into the system, it is controlled via workflow and audit logs, and updates when the condition is first approved, and then again when it is completed (i.e., sent to the reporting agency; for example, the CDC). EpiAnywhere is strictly a registry and reporting/analyzing service; it does not react to surveillance in real time.

General System Functionality

EpiAnywhere is an easy-to-use system for surveillance data entry. The interface is intuitive, and provides data validation, assisting the user to properly submit reportable condition forms. The interface is uncluttered and sequential, and shows a snapshot of the form one screen at a time. The other strength of EpiAnywhere is in reporting; the system provides the ability to create and use metrics and to gather stats

| Profile | |  |
|-------------------------|--|---|
| System | EpiAnywhere | |
| Company | EpiAnywhere, LLC | |
| Address | 215 Legion Way SW Olympia, WA 98501 | |
| Size of Company | 1-10 | |
| Current Implementations | 4 states, 4 countries | |
| Years in existence | 3 | |
| Main Contact Info | Joe Kabel, Ph.D, President Looking Glass Analytics, Inc. Office: (360) 570-7531 Email: joe.kabel@lgan.com | |

on the data collected. This includes the flexibility for the end user to import formulas and define different thresholds.

EpiAnywhere is cloud-based, so all data are stored in a SQL database at an EpiAnywhere facility, encrypted and secured behind the EpiAnywhere firewall. The EpiAnywhere facility meets all HIPAA requirements. All that is required to access EpiAnywhere is a browser and Microsoft Silverlight (an add-in program that the front-end is based on). The messaging from the system to the CDC is controlled by the Public Health Information Network Messaging System (PHINMS), which is regulated by the CDC. EpiAnywhere does not follow any type of release schedule, as new modules are configured or added as needed, and are then available to the entire customer base. There are relatively few bug fixes because the system does not change often. When it does, the user interface is rarely affected. Technical support is available within a 24 hour period, via phone and email. There is an annual subscription to use EpiAnywhere.

This Analysis: A Platform to Launch A Vendor Selection

This analysis does not seek to score, rank, or recommend any specific vendor. The “classifications” are used to align systems so that they can be compared, but the analysis itself represents a point-in-time snapshot of the functionality of these systems. Functionalities will certainly change in the future. In addition, here are some other factors to keep in mind when assessing your options:

- Actual cost of implementing the systems is not included. This is because the amount of configuration and customization can greatly change both upfront costs and ongoing maintenance costs. In addition, the vendors do not have set pricing schedules and everything is negotiable.
- Timing of the implementation should play a part in your decision-making process. As with any enterprise level system, highly customized systems will most likely take a significant amount of time and effort to implement. This information can be scoped with the vendors.
- Consider the readiness of your organization before selecting a system. There can be a large change management component around the implementation of a new system, so your user base needs to be ready.
- Find other public health agencies who have implemented the systems to get a current end-user’s viewpoint on the system as a whole, including any unforeseen costs or issues.

Follow these steps to determine which system is right for you:

Figure 3 – Vendor Selection Steps

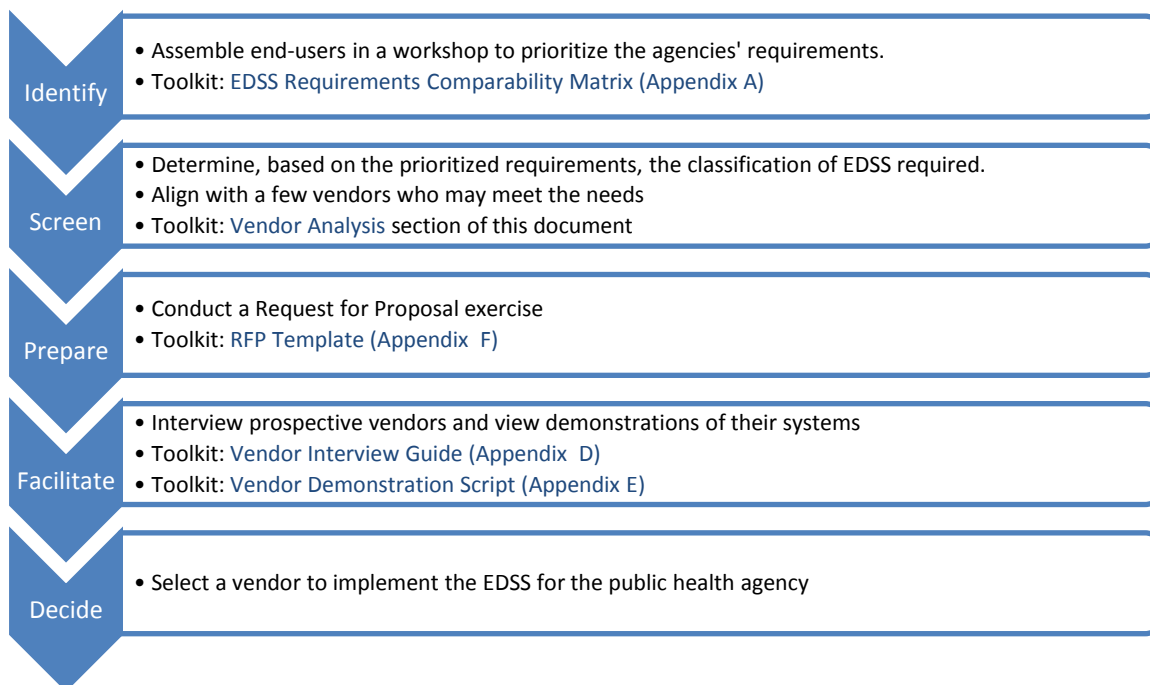

Appendix A: Requirement Comparability Matrix

Table 3 – Comparability Matrix Assessment Definitions

| Assessment | Symbol | Definition |
|-----------------------------|--------|--|
| Fully Meets Requirement | ● | The assessors have determined that the system satisfactorily meets all parts of the requirement |
| Partially Meets Requirement | ◐ | The assessors have determined that the system meets some or most of the requirement but does not “Fully Meet” the requirement. |
| Does Not Meet Requirement | ○ | The assessors have determined that the system does not meet the requirement. These fall into two categories; one where the requirement is intentionally not supported, and two, where the requirement is supported but not satisfactory. |

1.1 Reportable Conditions Surveillance Core Module

| 1.1 | Requirements Comparability Matrix – Reportable Conditions Surveillance | HealthSIS | EpiAnywhere | MAVEN | TriSano | WorldCare | NBS | Sentinel |
|-------|---|-----------|-------------|-------|---------|-----------|-----|----------|
| | Legend: ● Fully Meets Requirement ◐ Partially Meets Requirement ○ Does Not Meet Requirement | | | | | | | |
| | Condition Identification and Reporting | | | | | | | |
| 1.1.1 | Allow user to configure filter parameters (i.e. based on jurisdictional rules) | ● | ● | ● | ● | ● | ● | ● |
| 1.1.2 | Send communication to sender to notify of the receipt of conditions report | ◐ | ○ | ● | ○ | ● | ● | ○ |
| 1.1.3 | Support specific laboratory testing requirements for each condition | ● | ○ | ● | ● | ● | ● | ● |
| 1.1.4 | Flag records to indicate when laboratory report results has been received | ● | ● | ● | ● | ● | ● | ● |

| 1.1 | Requirements Comparability Matrix – Reportable Conditions Surveillance Legend: ● Fully Meets Requirement ● Partially Meets Requirement ○ Does Not Meet Requirement | HealthSIS | EpiAnywhere | MAVEN | Trisano | WorldCare | NBS | Sentinel |
|--|--|-----------|-------------|-------|---------|-----------|-----|----------|
| Condition Identification and Reporting (cont'd) | | | | | | | | |
| 1.1.5 | Support multiple lab formats for specimen type; test performed; quantity of specimen available; specimen quality (e.g., how stored, how long stored) | ● | ○ | ● | ● | ● | ● | ● |
| Event Identification and Validation | | | | | | | | |
| 1.1.6 | Ability to receive laboratory messages in a standard format; with the ability to adjust format | ● | ○ | ● | ● | ● | ● | ● |
| 1.1.7 | Maintain directories of searchable data sources, including type of data contained, organized by jurisdictional area | ○ | ○ | ● | ● | ● | ○ | ● |
| 1.1.8 | Allow user to utilize geo/temporal methods to identify events | ● | ○ | ● | ● | ● | ● | ● |
| 1.1.9 | Support the use of algorithms to identify events | ○ | ○ | ● | ● | ● | ● | ● |
| 1.1.10 | Have the ability to recognize event trends | ○ | ○ | ● | ● | ● | ● | ● |
| 1.1.11 | Have the ability to classify data into syndromes based on user-defined criteria | ● | ○ | ● | ● | ● | ● | ○ |
| 1.1.12 | Utilize pre-defined criteria for grouping data | ● | ● | ● | ● | ● | ● | ● |
| 1.1.13 | Have the ability to group data across different sources | ● | ○ | ● | ● | ● | ● | ● |
| 1.1.14 | Promote case routing to respective program areas within the system | ○ | ● | ● | ● | ● | ● | ● |
| 1.1.15 | Utilize user-defined priority thresholds that can be outlined in definitions | ○ | ○ | ● | ● | ● | ● | ● |
| 1.1.16 | Have ability to re-categorize or regroup data based on the introduction of new data | ● | ● | ● | ● | ● | ● | ● |
| 1.1.17 | Support versioning of rules and data | ● | ● | ● | ● | ● | ● | ● |
| 1.1.18 | Allow discrete pieces of data to be categorized in multiple ways | ● | ● | ● | ● | ● | ● | ● |

| 1.1 | Requirements Comparability Matrix – Reportable Conditions Surveillance | HealthSIS | EpiAnywhere | MAVEN | Trisano | WorldCare | NBS | Sentinel |
|---|--|-----------|-------------|-------|---------|-----------|-----|----------|
| | | | | | | | | |
| Event Identification and Validation (cont'd) | | | | | | | | |
| 1.1.9 | Have the ability to match event to existing data | ● | ○ | ● | ● | ● | ● | ● |
| 1.1.20 | Utilize user-defined/modified thresholds for matching events to cases | ● | ○ | ● | ● | ● | ● | ● |
| 1.1.21 | Facilitate both a manual and automated method to validate a previously reported case | ○ | ○ | ● | ● | ● | ● | ● |
| 1.1.22 | Have the ability to log any new data obtained | ● | ● | ● | ● | ● | ● | ● |
| 1.1.23 | Have the ability to match and update any new data obtained | ● | ○ | ● | ● | ● | ● | ● |
| 1.1.24 | Have the ability to alert user that a match/partial match has been made | ○ | ○ | ● | ● | ● | ● | ● |
| 1.1.25 | Have the ability to view and query updates | ● | ◐ | ● | ● | ● | ● | ● |
| 1.1.26 | Support algorithms for evaluation of event data (Provide decision support) | ○ | ○ | ● | ● | ● | ● | ● |
| 1.1.27 | Allow data to link to event management | ○ | ○ | ● | ● | ● | ● | ● |
| 1.1.28 | Have the ability to set user-defined algorithms based on conditions (Example: Use algorithm to weight the data streams or events. Could also include symptoms, time of year, geography, number of notifications) | ○ | ○ | ● | ● | ● | ● | ● |
| 1.1.29 | Have the ability to perform automated analysis with manual override | ○ | ○ | ● | ● | ● | ● | ○ |
| 1.1.30 | Have the ability to weight/rate all events (Triage events so that system goes after higher priority first) | ● | ○ | ● | ● | ● | ● | ● |
| 1.1.31 | Have ability to appropriately route referrals for additional investigation within agency/programs | ○ | ○ | ● | ● | ● | ● | ● |
| 1.1.32 | Have the ability to log the event if additional investigation is not warranted | ● | ○ | ● | ● | ● | ● | ● |
| 1.1.33 | Provide explanation for why it is/is not suggesting investigation | ○ | ○ | ● | ● | ● | ● | ● |

| 1.1 | Requirements Comparability Matrix – Reportable Conditions Surveillance | HealthSIS | EpiAnywhere | MAVEN | Trisano | WorldCare | NBS | Sentinel |
|--|--|----------------------------------|----------------------------------|----------------------------------|----------------------------------|----------------------------------|----------------------------------|----------------------------------|
| Legend: <input checked="" type="radio"/> Fully Meets Requirement <input type="radio"/> Partially Meets Requirement <input type="radio"/> Does Not Meet Requirement | | | | | | | | |
| Case Investigation | | | | | | | | |
| 1.1.34 | Support versioning of data with retrieval capabilities | <input type="radio"/> | <input type="radio"/> | <input checked="" type="radio"/> | <input checked="" type="radio"/> | <input checked="" type="radio"/> | <input checked="" type="radio"/> | <input checked="" type="radio"/> |
| 1.1.35 | Ability to assign it to an investigator, capturing the date of assignment | <input type="radio"/> | <input type="radio"/> | <input checked="" type="radio"/> | <input checked="" type="radio"/> | <input checked="" type="radio"/> | <input checked="" type="radio"/> | <input checked="" type="radio"/> |
| 1.1.36 | Ability to generate a new case from a contact record | <input type="radio"/> | <input type="radio"/> | <input checked="" type="radio"/> | <input checked="" type="radio"/> | <input checked="" type="radio"/> | <input checked="" type="radio"/> | <input checked="" type="radio"/> |
| 1.1.37 | Ability to accept/reject case based upon signoff definition | <input type="radio"/> | <input type="radio"/> | <input checked="" type="radio"/> | <input checked="" type="radio"/> | <input checked="" type="radio"/> | <input checked="" type="radio"/> | <input checked="" type="radio"/> |
| 1.1.38 | Have the ability to send and receive needed forms from care providers | <input type="radio"/> | <input type="radio"/> | <input checked="" type="radio"/> | <input checked="" type="radio"/> | <input checked="" type="radio"/> | <input type="radio"/> | <input type="radio"/> |
| 1.1.39 | Allow user to design and save form templates | <input type="radio"/> | <input type="radio"/> | <input checked="" type="radio"/> | <input checked="" type="radio"/> | <input checked="" type="radio"/> | <input checked="" type="radio"/> | <input type="radio"/> |
| 1.1.40 | Allow user to create and save questionnaire | <input type="radio"/> | <input type="radio"/> | <input checked="" type="radio"/> | <input checked="" type="radio"/> | <input checked="" type="radio"/> | <input checked="" type="radio"/> | <input checked="" type="radio"/> |
| 1.1.41 | Allow for multiple methods of data entry (manual, scanning, optical character reader) | <input type="radio"/> | <input type="radio"/> | <input checked="" type="radio"/> | <input checked="" type="radio"/> | <input checked="" type="radio"/> | <input checked="" type="radio"/> | <input type="radio"/> |
| 1.1.42 | Identify source of information | <input type="radio"/> | <input checked="" type="radio"/> | <input checked="" type="radio"/> | <input checked="" type="radio"/> | <input checked="" type="radio"/> | <input checked="" type="radio"/> | <input checked="" type="radio"/> |
| 1.1.43 | Allow user to attach documents and images related to a specific case | <input type="radio"/> | <input type="radio"/> | <input checked="" type="radio"/> | <input checked="" type="radio"/> | <input checked="" type="radio"/> | <input checked="" type="radio"/> | <input checked="" type="radio"/> |
| 1.1.44 | Support an algorithm to perform risk evaluation prioritization of the case | <input type="radio"/> | <input type="radio"/> | <input checked="" type="radio"/> | <input type="radio"/> | <input checked="" type="radio"/> | <input type="radio"/> | <input type="radio"/> |
| 1.1.45 | Allow user to assign and override priority based on evaluation | <input type="radio"/> | <input type="radio"/> | <input checked="" type="radio"/> | <input checked="" type="radio"/> | <input checked="" type="radio"/> | <input checked="" type="radio"/> | <input checked="" type="radio"/> |
| 1.1.46 | Allow user to store prioritized data elements (disease specific) | <input type="radio"/> | <input type="radio"/> | <input checked="" type="radio"/> | <input checked="" type="radio"/> | <input checked="" type="radio"/> | <input checked="" type="radio"/> | <input checked="" type="radio"/> |
| 1.1.47 | Have ability to prompt user when contact tracing is necessary based on reported condition | <input type="radio"/> | <input type="radio"/> | <input checked="" type="radio"/> | <input type="radio"/> | <input checked="" type="radio"/> | <input type="radio"/> | <input type="radio"/> |
| 1.1.48 | Ability to evaluate criteria to determine like-kind demographic linkages (boyfriend/girlfriend residing at the same address, home phone, etc.) | <input type="radio"/> | <input type="radio"/> | <input checked="" type="radio"/> | <input type="radio"/> | <input checked="" type="radio"/> | <input type="radio"/> | <input type="radio"/> |
| 1.1.49 | Ability to track multiple instances of like locators (geographic, telephonic, or electronic locator) | <input checked="" type="radio"/> | <input checked="" type="radio"/> | <input checked="" type="radio"/> | <input checked="" type="radio"/> | <input checked="" type="radio"/> | <input checked="" type="radio"/> | <input checked="" type="radio"/> |

| 1.1 | Requirements Comparability Matrix – Reportable Conditions Surveillance Legend: ● Fully Meets Requirement ● Partially Meets Requirement ○ Does Not Meet Requirement | HealthSIS | EpiAnywhere | MAVEN | Trisano | WorldCare | NBS | Sentinel |
|------------------------------------|--|-----------|-------------|-------|---------|-----------|-----|----------|
| Case Investigation (cont'd) | | | | | | | | |
| 1.1.50 | Ability to track multiple instances of like identifiers assigned by external systems (driver's license, patient id, health card id, etc.) | ● | ● | ● | ● | ● | ● | ● |
| 1.1.51 | Facilitate the recording of standard demographic information (race, ethnicity, etc.) as well as be extensible in nature to allow for multiple of these instances to be captured within the same area | ● | ● | ● | ● | ● | ● | ● |
| 1.1.52 | Ability to define legal responsibility (parent, representative, legal guardian), and attach the appropriate documentation to the functional area | ● | ● | ● | ● | ● | ● | ● |
| 1.1.53 | Provide the capability to track multiple laboratory reports for an individual case; designating the source of the report whether it be manual or ELR | ● | ● | ● | ● | ● | ● | ● |
| 1.1.54 | Provide the functionality to track multiple results for a sign or symptom | ● | ● | ● | ● | ● | ● | ● |
| 1.1.55 | Ability to track source of exposure | ● | ● | ● | ● | ● | ● | ● |
| 1.1.56 | Support configurable auto-classification based on user-defined criteria (i.e. disease/condition and jurisdiction specific) | ○ | ○ | ● | ● | ● | ● | ○ |
| 1.1.57 | Automatically suggest and update classification, based on all information gathered at any point in case investigation | ● | ● | ● | ● | ● | ● | ○ |
| 1.1.58 | Support tracking of case definition changes | ○ | ○ | ● | ● | ● | ● | ● |
| 1.1.59 | Assign case definition at time of incidence or report | ○ | ● | ● | ● | ● | ● | ● |
| 1.1.60 | Display data element involved in the environmental investigation (Audit trail) | ○ | ○ | ● | ● | ● | ● | ● |
| 1.1.61 | Automatically prompt user when an outbreak investigation | ○ | ○ | ● | ● | ● | ○ | ○ |

| 1.1 | Requirements Comparability Matrix – Reportable Conditions Surveillance Legend: ● Fully Meets Requirement ● Partially Meets Requirement ○ Does Not Meet Requirement | HealthSIS | EpiAnywhere | MAVEN | Trisano | WorldCare | NBS | Sentinel |
|------------------------------------|--|-----------|-------------|-------|---------|-----------|-----|----------|
| Case Investigation (cont'd) | | | | | | | | |
| 1.1.62 | Allow user to assign a status to the case | ● | ● | ● | ● | ● | ● | ● |
| 1.1.63 | Allow user to save all case information | ● | ● | ● | ● | ● | ● | ● |
| 1.1.64 | Record person closing case, and time of closing (audit log) | ● | ● | ● | ● | ● | ● | ● |
| Contact Tracing | | | | | | | | |
| 1.1.65 | Ability to link to other uniquely defined persons in the database | ○ | ○ | ● | ● | ● | ● | ● |
| 1.1.66 | Ability to generate a new case from a contact record | ○ | ○ | ● | ● | ● | ● | ● |
| 1.1.67 | Ability to visually represent contact linkage via the contact web (Pin map) | ○ | ○ | ● | ● | ● | ○ | ● |
| 1.1.68 | Ability to record multiple encounters for each case including the mood code | ● | ● | ● | ● | ● | ● | ● |
| 1.1.69 | Allow user to capture contact information (address, phone number, email address, photos, etc...) and risk factor data | ● | ● | ● | ● | ● | ● | ● |
| 1.1.70 | Allow user to upload list of contacts from spreadsheets | ○ | ○ | ● | ● | ● | ● | ● |
| 1.1.71 | Allow user to categorize contacts per user defined characteristics | ○ | ○ | ● | ● | ● | ○ | ● |
| 1.1.72 | Allow user to sort contact list by user defined characteristics | ○ | ● | ● | ● | ● | ○ | ● |
| 1.1.73 | Allow user to send communications to care providers to identify contacts (interface with EHR systems) | ○ | ○ | ● | ● | ● | ○ | ● |
| 1.1.74 | Allow user to associate contact with index case | ○ | ○ | ● | ● | ● | ● | ● |
| 1.1.75 | Support contact information for an aggregate investigation or an individual case (Obtain contact info for facility rather than individual) | ● | ● | ● | ● | ● | ○ | ● |

| 1.1 | Requirements Comparability Matrix – Reportable Conditions Surveillance Legend: ● Fully Meets Requirement ● Partially Meets Requirement ○ Does Not Meet Requirement | HealthSIS | EpiAnywhere | MAVEN | Trisano | WorldCare | NBS | Sentinel |
|---|--|-----------|-------------|-------|---------|-----------|-----|----------|
| Contact Tracing (cont'd) | | | | | | | | |
| 1.1.76 | Provide ability to support algorithms to determine priority | ○ | ○ | ● | ○ | ● | ○ | ○ |
| 1.1.77 | Allow user to type information/notes in free-form text box | ● | ● | ● | ● | ● | ● | ● |
| 1.1.78 | Support ability to manage/track interview status | ○ | ● | ● | ● | ● | ○ | ● |
| 1.1.79 | Support ability to sort contacts based on interview status | ○ | ○ | ● | ● | ● | ○ | ● |
| 1.1.80 | Provide ability to prioritize contact follow-up | ○ | ○ | ● | ● | ● | ● | ○ |
| 1.1.81 | Support ability to track/note any instructional communications sent. Record case related workflow activities (phone call, send a letter, notification, etc.) | ○ | ○ | ● | ● | ● | ○ | ● |
| Case/Contact Specific Intervention | | | | | | | | |
| 1.1.82 | Display predefined intervention plans | ● | ○ | ● | ● | ● | ○ | ● |
| 1.1.83 | Allow user to select a predefined intervention plan | ● | ○ | ● | ● | ● | ○ | ● |
| 1.1.84 | Allow user to modify predefined intervention plans to include updated guidelines/metadata from CDC and other supporting information | ● | ○ | ● | ● | ● | ○ | ● |
| 1.1.85 | Allow user to add the intervention plan to an existing case record | ○ | ○ | ● | ● | ● | ○ | ● |
| 1.1.86 | Support interoperability with case management system | ● | ○ | ● | ● | ● | ● | ● |
| 1.1.87 | Allow user to create and save a customized intervention plan | ● | ○ | ● | ● | ● | ○ | ● |
| 1.1.88 | Have the ability to automatically suggest an intervention plan, based on the disease or condition | ● | ○ | ● | ● | ● | ○ | ● |
| 1.1.89 | Have the ability to send order sets to care provider/case management systems | ○ | ○ | ● | ● | ● | ○ | ● |

| 1.1 | Requirements Comparability Matrix – Reportable Conditions Surveillance | HealthSIS | EpiAnywhere | MAVEN | Trisano | WorldCare | NBS | Sentinel |
|---|---|-----------|-------------|-------|---------|-----------|-----|----------|
| Legend: ● Fully Meets Requirement ● Partially Meets Requirement ○ Does Not Meet Requirement | | | | | | | | |
| Case/Contact Specific Intervention (cont'd) | | | | | | | | |
| 1.1.90 | Allow user to select a recommended treatment plan | ○ | ○ | ● | ● | ● | ○ | ● |
| 1.1.91 | Allow user to transmit recommendations to care provider/case management systems | ○ | ○ | ● | ● | ● | ○ | ● |
| 1.1.92 | Have ability to populate forms using information from an external system | ○ | ○ | ● | ● | ● | ● | ● |
| 1.1.93 | Allow user to document patient/contact treatment details and diagnostics | ○ | ○ | ● | ● | ● | ○ | ● |
| 1.1.94 | Allow for parameters to be established for distinct conditions | ○ | ○ | ● | ● | ● | ○ | ● |
| 1.1.95 | Have the ability to connect with pharmacy data to track filling of prescriptions | ○ | ○ | ● | ● | ○ | ○ | ○ |
| 1.1.96 | Have the ability to receive test reports and attach to case/contact | ○ | ● | ● | ● | ● | ● | ● |
| 1.1.97 | Allow user to document and save treatment and outcome information | ○ | ○ | ● | ● | ● | ● | ● |
| 1.1.98 | Provide the ability to transmit order sets and clinical pathways to provider/case manager | ○ | ○ | ● | ● | ○ | ○ | ● |
| 1.1.99 | Have the ability to alert user of missed events | ○ | ○ | ● | ● | ● | ○ | ● |
| 1.1.100 | Have the ability to alert user of follow-up test and other diagnostic results | ○ | ○ | ● | ● | ● | ○ | ● |
| 1.1.101 | Have the ability to interact with other systems to determine status of intervention | ○ | ○ | ● | ● | ● | ○ | ● |
| 1.1.102 | Alert user that case is moving out of infectious time period or incubation time period after infections | ○ | ○ | ● | ● | ● | ○ | ○ |
| 1.1.103 | Provide the ability to link a case to an index case | ○ | ○ | ● | ● | ● | ● | ○ |
| 1.1.104 | Provide the ability to generate progress notes and other documentation | ○ | ○ | ● | ● | ● | ○ | ● |
| 1.1.105 | Have the ability to alert user if anyone identified as a contact subsequently becomes a case | ○ | ○ | ● | ● | ● | ○ | ○ |

| 1.1 | Requirements Comparability Matrix – Reportable Conditions Surveillance | HealthSIS | EpiAnywhere | MAVEN | Trisano | WorldCare | NBS | Sentinel |
|--|--|---|-------------|-------|---------|-----------|-----|----------|
| | | Legend: ● Fully Meets Requirement ● Partially Meets Requirement ○ Does Not Meet Requirement | | | | | | |
| Case/Contact Specific Intervention (cont'd) | | | | | | | | |
| 1.1.106 | Have ability to auto-suggest to close case based on defined criteria | ○ | ○ | ● | ● | ● | ● | ○ |
| 1.1.107 | Allow users to retrieve information from case management system | ○ | ○ | ● | ● | ● | ● | ○ |
| 1.1.108 | Allow user to send/receive alert from case management system | ○ | ○ | ● | ● | ● | ● | ● |
| 1.1.109 | Identify when appropriate time periods have lapsed to close case | ○ | ○ | ● | ● | ● | ● | ● |
| 1.1.110 | Allow user to configure an algorithm to have system automatically assign closure justification to case | ○ | ○ | ● | ○ | ● | ● | ○ |
| 1.1.111 | Allow user to manually assign closure justification to a case | ○ | ○ | ● | ● | ● | ● | ● |
| Event/Outbreak Management | | | | | | | | |
| 1.1.112 | Support multiple distribution methods for communications | ○ | ○ | ● | ● | ● | ○ | ● |
| 1.1.113 | Support methods to collect feedback concerning communication | ○ | ○ | ● | ● | ● | ○ | ● |
| 1.1.114 | Maintain a library of previous outbreak or event management plans | ○ | ○ | ● | ● | ● | ○ | ● |
| 1.1.115 | Allow user to generate, edit and save outbreak plans | ○ | ○ | ● | ● | ● | ○ | ● |
| 1.1.116 | Allow user to document best practices by disease/condition | ○ | ○ | ● | ● | ● | ○ | ○ |
| 1.1.117 | Maintain template library of outbreak plans | ○ | ○ | ● | ● | ● | ○ | ● |
| 1.1.118 | Create dashboard of activities based on generated plan | ○ | ○ | ● | ● | ● | ○ | ● |
| 1.1.119 | Support interface with the Incident Command System (ICS) | ○ | ○ | ● | ● | ● | ○ | ● |
| 1.1.120 | Be able to store data from external sources at individual or outbreak-level | ○ | ○ | ● | ● | ● | ○ | ● |

| 1.1 | Requirements Comparability Matrix – Reportable Conditions Surveillance Legend: ● Fully Meets Requirement ● Partially Meets Requirement ○ Does Not Meet Requirement | HealthSIS | EpiAnywhere | MAVEN | Trisano | WorldCare | NBS | Sentinel |
|---|--|-----------|-------------|-------|---------|-----------|-----|----------|
| Event/Outbreak Management (cont'd) | | | | | | | | |
| 1.1.121 | Track number of cases (confirmed/probable) by geography/setting and all other demographic information (e.g., age group, sex) | ○ | ○ | ● | ● | ● | ● | ● |
| 1.1.122 | Monitor data streams based on user-defined criteria (e.g. syndromic data, diagnostic testing, absenteeism, OTC medication sales, etc.) | ○ | ○ | ● | ○ | ○ | ○ | ○ |
| 1.1.123 | Monitor type and number of tests ordered by care providers | ○ | ○ | ● | ○ | ○ | ○ | ○ |
| 1.1.124 | Monitor chief complaints | ○ | ○ | ● | ○ | ○ | ○ | ○ |
| 1.1.125 | Monitor/receive reports about purchasing of over-the-counter medications | ○ | ○ | ● | ○ | ○ | ○ | ○ |
| 1.1.126 | Monitor emergency department admissions | ○ | ○ | ● | ○ | ○ | ○ | ○ |
| 1.1.127 | Monitor any new/identified data source | ○ | ○ | ● | ● | ○ | ○ | ○ |
| 1.1.128 | Provide real-time monitor feeds and views | ○ | ○ | ● | ● | ○ | ○ | ○ |
| 1.1.129 | Allow the user to create/define, edit, and save metrics on interventions/control/prevention | ○ | ○ | ● | ● | ● | ○ | ● |
| 1.1.130 | Have the ability to regularly update epidemiologic curves | ● | ○ | ● | ● | ● | ● | ● |
| 1.1.131 | Alert user of outstanding tasks in the outbreak management plan | ○ | ● | ● | ● | ● | ○ | ● |
| 1.1.132 | Allow user to create, edit, and save user-defined templates for media reporting | ○ | ○ | ● | ● | ● | ○ | ○ |
| 1.1.133 | Store contact information for distribution of communications | ○ | ○ | ● | ● | ● | ○ | ● |
| 1.1.134 | Support creation of after-action reports | ○ | ○ | ● | ● | ● | ○ | ● |
| 1.1.135 | Allow user to create, edit and save event records | ○ | ○ | ● | ● | ● | ○ | ● |

| 1.1 | Requirements Comparability Matrix – Reportable Conditions Surveillance Legend: ● Fully Meets Requirement ● Partially Meets Requirement ○ Does Not Meet Requirement | HealthSIS | EpiAnywhere | MAVEN | Trisano | WorldCare | NBS | Sentinel |
|---|--|-----------|-------------|-------|---------|-----------|-----|----------|
| Event/Outbreak Management (cont'd) | | | | | | | | |
| 1.1.136 | Assign to event record creation date and unique record number, derived from the originating system | ○ | ○ | ● | ● | ● | ● | ● |
| 1.1.137 | Identify creator of the new record | ● | ○ | ● | ● | ● | ● | ● |
| 1.1.138 | Allow user to update communication plan with information from partner communications | ○ | ○ | ● | ● | ● | ○ | ○ |
| 1.1.139 | Support interoperability with systems such as EHRs, etc. | ○ | ○ | ● | ● | ● | ○ | ● |
| 1.1.140 | Track communication outcome and measures for reporting and refining activities | ○ | ○ | ● | ● | ● | ○ | ● |
| 1.1.141 | Maintain templates for external/internal communications | ○ | ○ | ● | ● | ● | ○ | ● |
| 1.1.142 | Be able to organize data by relevant data sources | ○ | ○ | ● | ● | ● | ○ | ● |
| 1.1.143 | Generate tables that present summary statistics of key variables, including completeness, frequencies, and means | ○ | ○ | ● | ● | ● | ● | ● |
| 1.1.144 | Allow user to analyze by demographic and geographic subgroups | ○ | ● | ● | ● | ● | ● | ● |
| 1.1.145 | Allow user to program new analytic methods into system or import formulas or define new thresholds | ○ | ○ | ● | ● | ● | ○ | ● |
| 1.1.146 | Have the ability to detect temporal and spacial clustering of cases | ○ | ○ | ● | ● | ● | ○ | ○ |
| 1.1.147 | Allow user to create, edit, and save templates to document investigation | ○ | ○ | ● | ● | ● | ○ | ● |
| 1.1.148 | Maintain a searchable library of established/historical outbreak case definitions | ○ | ○ | ● | ● | ● | ● | ● |
| 1.1.149 | Have the ability to link cases to outbreaks | ○ | ○ | ● | ● | ● | ○ | ● |
| 1.1.150 | Have the ability to assign outbreak definitions by jurisdiction | ○ | ○ | ● | ● | ● | ○ | ● |
| 1.1.151 | Identify new cases based on newly-assigned outbreak definition | ○ | ○ | ● | ● | ● | ○ | ● |

| 1.1 | Requirements Comparability Matrix – Reportable Conditions Surveillance Legend: ● Fully Meets Requirement ● Partially Meets Requirement ○ Does Not Meet Requirement | HealthSIS | EpiAnywhere | MAVEN | Trisano | WorldCare | NBS | Sentinel |
|---|--|-----------|-------------|-------|---------|-----------|-----|----------|
| Event/Outbreak Management (cont'd) | | | | | | | | |
| 1.1.152 | Have the ability to link to the environmental investigation system or import relevant environmental data as needed | ○ | ○ | ● | ● | ● | ○ | ● |
| 1.1.153 | Send test order to healthcare provider and laboratory | ○ | ○ | ● | ○ | ● | ○ | ○ |
| 1.1.154 | Have the ability to automatically link test results based on user-defined key, code or other selected information that is included with request for testing | ○ | ○ | ● | ● | ● | ○ | ○ |
| 1.1.155 | Have the ability to link to case/contact-specific intervention record | ○ | ○ | ● | ● | ● | ○ | ● |
| 1.1.156 | Trigger case classification in condition identification and reporting, based on outbreak definition | ○ | ○ | ● | ● | ● | ○ | ● |
| 1.1.157 | Support use of tools for specific statistical/analytic methods | ● | ● | ● | ● | ● | ● | ● |
| 1.1.158 | Support reminders of incomplete questionnaires/non-responses | ○ | ○ | ● | ● | ● | ○ | ● |
| 1.1.159 | Have the ability to link questionnaires to case investigation | ○ | ○ | ● | ● | ● | ○ | ● |
| 1.1.160 | Maintain multiple disease/condition/outbreak-specific classification criteria | ○ | ○ | ● | ● | ● | ○ | ● |
| 1.1.161 | Interface with public health registries | ○ | ○ | ● | ● | ● | ● | ○ |
| 1.1.162 | Allow user to classify contacts based on location and/or risk factors | ○ | ○ | ● | ● | ● | ○ | ● |
| 1.1.163 | Allow user to upload lists of contacts from spreadsheets or other documents | ○ | ○ | ● | ● | ● | ○ | ● |
| 1.1.164 | Perform validation of contact information formatting and alert user of invalid data | ● | ○ | ● | ● | ● | ● | ● |
| 1.1.165 | Have the ability to link contacts with index case | ○ | ○ | ● | ● | ● | ● | ● |
| 1.1.166 | Manage/track interview status and follow-up | ○ | ○ | ● | ● | ● | ○ | ● |

| 1.1 | Requirements Comparability Matrix – Reportable Conditions Surveillance Legend: ● Fully Meets Requirement ● Partially Meets Requirement ○ Does Not Meet Requirement | HealthSIS | EpiAnywhere | MAVEN | Trisano | WorldCare | NBS | Sentinel |
|---|--|-----------|-------------|-------|---------|-----------|-----|----------|
| Event/Outbreak Management (cont'd) | | | | | | | | |
| 1.1.167 | Have the ability to receive and analyze survey responses | ○ | ○ | ● | ● | ○ | ○ | ● |
| 1.1.168 | Have the ability to graphically depict identified linked cases on a map (i.e. contact web) | ● | ○ | ● | ● | ● | ○ | ● |
| 1.1.169 | Allow user to set/modify exposure criteria | ○ | ○ | ● | ● | ● | ○ | ● |
| 1.1.170 | Automatically determine if contact meets exposure criteria | ○ | ○ | ● | ● | ● | ○ | ○ |
| 1.1.171 | Have ability to track distribution/receipt of education materials | ○ | ○ | ● | ● | ● | ○ | ○ |
| 1.1.172 | Support calculation of epidemiologic statistics | ○ | ● | ● | ● | ● | ● | ● |
| Public Health Alerts | | | | | | | | |
| 1.1.173 | Allow "receiving agency" to alert "sharing agency" of receipt /non receipt of data or problem(s) with data | ○ | ○ | ● | ○ | ● | ○ | ○ |
| 1.1.174 | Interface with public alert networks | ○ | ○ | ● | ● | ● | ● | ○ |
| 1.1.175 | Interface with social networks to send alerts | ○ | ○ | ○ | ○ | ○ | ○ | ○ |
| 1.1.176 | Allow user the ability to create/edit and send alert messages | ○ | ○ | ● | ● | ● | ● | ● |
| 1.1.177 | Utilize Home Area Network (HAN) Interface to transmit or receive information to smart devices in the home | ○ | ○ | ● | ● | ● | ● | ○ |

1.2 General System Requirements

| 1.2 | Requirements Comparability Matrix – General System Requirements | HealthSIS | EpiAnywhere | MAVEN | TriSano | WorldCare | NBS | Sentinel |
|--------|--|-----------|-------------|-------|---------|-----------|-----|----------|
| | Legend: ● Fully Meets Requirement ● Partially Meets Requirement ○ Does Not Meet Requirement | | | | | | | |
| | System Support | | | | | | | |
| 1.2.1 | System has supporting documentation | ● | ● | ● | ● | ● | ● | ● |
| 1.2.2 | Program has Release Notes, that accompany each release | ● | ● | ● | ● | ● | ● | ● |
| 1.2.3 | Program has multiple ways for end users to get help and training materials (i.e.: User Manuals, Use Cases, Online User Guides, Helpdesk Module to submit help tickets) | ● | ● | ● | ● | ● | ● | ● |
| | Functionality | | | | | | | |
| 1.2.4 | Allow workflow management | ● | ● | ● | ● | ● | ● | ● |
| 1.2.5 | Data can be imported to the program (Additional List of Supported Formats) | ● | ● | ● | ● | ● | ● | ● |
| 1.2.6 | Data can be exported from the program (Additional List of Supported Formats) | ● | ● | ● | ● | ● | ● | ● |
| 1.2.7 | Form Builder capability - Facilitate the customization of questionnaires on the fly | ○ | ○ | ● | ● | ● | ● | ● |
| 1.2.8 | Ability to import questionnaires from other systems | ○ | ○ | ● | ● | ● | ● | ● |
| 1.2.9 | Ability to reuse customized questionnaires | ○ | ● | ● | ● | ● | ● | ● |
| 1.2.10 | Ability to create and save letter templates | ○ | ○ | ● | ● | ● | ○ | ● |
| 1.2.11 | Software contains audit tracking capabilities (log, etc.) | ● | ● | ● | ● | ● | ● | ● |
| 1.2.12 | User -friendly data input validation and error handling (business rules) | ● | ● | ● | ● | ● | ● | ● |
| 1.2.13 | System generated messages/ emails/ notifications | ● | ● | ● | ● | ● | ● | ● |
| 1.2.14 | Data Quality Assurance/Quality Control functionality (report of validation errors) | ● | ● | ● | ● | ● | ● | ● |

| 1.2 | Requirements Comparability Matrix – General System Requirements | HealthSIS | EpiAnywhere | MAVEN | TriSano | WorldCare | NBS | Sentinel |
|------------------------------|---|-----------|-------------|-------|---------|-----------|-----|----------|
| | | | | | | | | |
| Functionality | | | | | | | | |
| 1.2.15 | Allow user to override to move on to next process step, even if elements are determined to be missing | ○ | ○ | ● | ○ | ● | ○ | ○ |
| 1.2.16 | Search functionality - Allow user to apply search filters, cross reference data and retrieve specific data matches | ● | ● | ● | ● | ● | ● | ● |
| 1.2.17 | Auto-complete/auto-suggest word functionality (i.e.: IntelliSense functionality) | ○ | ○ | ● | ● | ● | ○ | ● |
| 1.2.18 | Program supports multiple languages | ○ | ○ | ● | ● | ● | ○ | ○ |
| 1.2.19 | Provides a sandbox environment to test in | ● | ● | ● | ● | ● | ● | ○ |
| System Administration | | | | | | | | |
| 1.2.20 | Program allows for system administration roles and responsibilities | ● | ● | ● | ● | ● | ● | ● |
| Data Capture | | | | | | | | |
| 1.2.21 | Supports multiple reportable conditions (see list of all nationally notifiable diseases in Appendix section) | ● | ● | ● | ● | ● | ● | ● |
| 1.2.22 | Allows for capturing data specific to Global Communicable Diseases (GCD) | ● | ● | ● | ● | ● | ● | ● |
| 1.2.23 | Allows for capturing data specific to Vaccine Preventable Diseases (VPD) | ● | ● | ● | ● | ● | ● | ● |
| 1.2.24 | Allows for capturing data specific to Hepatitis B | ● | ○ | ● | ● | ● | ● | ● |
| 1.2.25 | Allows for capturing data specific to Hepatitis C | ● | ○ | ● | ● | ● | ● | ● |
| 1.2.26 | Allows for capturing data specific to Tuberculosis | ● | ● | ● | ● | ● | ● | ● |
| 1.2.27 | Allows for capturing data specific to Sexually Transmitted Diseases (Gonorrhea, Chlamydia, Syphilis and other STDs) | ● | ● | ● | ● | ● | ○ | ● |
| 1.2.28 | Allows for capturing data specific to HIV/AIDS | ○ | ● | ● | ● | ● | ○ | ● |

| 1.2 | Requirements Comparability Matrix – General System Requirements Legend: ● Fully Meets Requirement ● Partially Meets Requirement ○ Does Not Meet Requirement | HealthSIS | EpiAnywhere | MAVEN | Trisano | WorldCare | NBS | Sentinel |
|------------------------------|---|-----------|-------------|-------|---------|-----------|-----|----------|
| Data Capture (cont'd) | | | | | | | | |
| 1.2.29 | Allows for capturing data specific to Condition Reporting | ● | ● | ● | ● | ● | ● | ● |
| 1.2.30 | Allows for capturing data specific to Case Identification | ● | ● | ● | ● | ● | ● | ● |
| 1.2.31 | Allows for capturing data specific to Case investigation | ○ | ● | ● | ● | ● | ● | ● |
| 1.2.32 | Allows for capturing data specific to Contact Tracing | ○ | ○ | ● | ● | ● | ● | ● |
| 1.2.33 | Allows for capturing data specific to Case/Contact Specific Intervention | ○ | ○ | ● | ● | ● | ○ | ● |
| 1.2.34 | Allows for capturing data specific to Event/ Outbreak Management | ○ | ○ | ● | ● | ● | ○ | ● |
| 1.2.35 | Allows for both receiving and distributing Public Health Alerts | ○ | ○ | ● | ● | ● | ● | ● |
| 1.2.36 | Program provides a case centric view of the data to the end user | ○ | ● | ● | ● | ● | ● | ● |
| 1.2.37 | Program provides a Person-centric view of the data to the end user | ● | ○ | ● | ● | ● | ● | ● |
| 1.2.38 | Program supports user defined validation. | ● | ● | ● | ● | ● | ● | ● |

1.3 Technical Design

| 1.3 | Requirements Comparability Matrix – Technical Design Legend: ● Fully Meets Requirement ● Partially Meets Requirement ○ Does Not Meet Requirement | HealthSIS | EpiAnywhere | MAVEN | TriSano | WorldCare | NBS | Sentinel |
|--------|---|-----------|-------------|-------|---------|-----------|-----|----------|
| | | | | | | | | |
| | Technical Design and Architecture | | | | | | | |
| 1.3.1 | Program meets best practices for Technical Design and architecture | ● | ● | ● | ● | ● | ● | ● |
| 1.3.2 | Program is on a platform which is supported and will be supported in the near future | ● | ● | ● | ● | ● | ● | ● |
| 1.3.3 | Support client-server environment | ● | ● | ● | ● | ● | ● | ● |
| 1.3.4 | Uses SOA architecture | ● | ● | ● | ● | ● | ○ | ● |
| 1.3.5 | Supports a modular design | ● | ● | ● | ● | ● | ● | ● |
| 1.3.6 | Supports multiple users | ● | ● | ● | ● | ● | ● | ● |
| 1.3.7 | Program is developed in a language that is supported and will be supported in the future | ● | ● | ● | ● | ● | ● | ● |
| | Security / Privacy | | | | | | | |
| 1.3.8 | Compliant with national computer security standards & technology - Federal Info Processing Stds (FIPs 140-2) | ● | ● | ● | ● | ● | ● | ● |
| 1.3.9 | System recovery and backup system functions (frequent archiving of data) | ● | ● | ● | ● | ● | ● | ● |
| 1.3.10 | Microsoft Active Directory & Lightweight Directory Access Protocol capable | ● | ● | ● | ● | ● | ● | ● |
| 1.3.11 | Program offers users single sign on functionality | ● | ○ | ● | ○ | ● | ● | ○ |
| 1.3.12 | TLS 1.0 or SSL 3.1 is supported | ● | ● | ● | ● | ● | ● | ● |
| 1.3.13 | Automatic password expiry definable | ● | ● | ● | ● | ● | ○ | ● |
| 1.3.14 | Stored passwords are encrypted | ● | ● | ● | ● | ● | ○ | ● |

| 1.3 | Requirements Comparability Matrix – Technical Design | HealthSIS | EpiAnywhere | MAVEN | Trisano | WorldCare | NBS | Sentinel |
|-----------------------------|---|-----------|-------------|-------|---------|-----------|-----|----------|
| | | | | | | | | |
| Security / Privacy (cont'd) | | | | | | | | |
| 1.3.15 | Security violations are automatically logged | ● | ● | ● | ● | ● | ○ | ● |
| 1.3.16 | Program provides ability to use role-based security | ● | ● | ● | ● | ● | ● | ● |
| 1.3.17 | Program will be HIPAA compliant | ● | ● | ● | ● | ● | ● | ● |
| 1.3.18 | Allows for secure data encryption while data are at rest | ● | ● | ● | ● | ● | ● | ● |
| 1.3.19 | Allows for secure data encryption while data are being transferred | ● | ● | ● | ● | ● | ● | ● |
| 1.3.20 | Support definitions of roles with assigned levels of access, viewing, data entry, editing and auditing | ● | ● | ● | ● | ● | ● | ● |
| 1.3.21 | Authenticate each user by role before allowing access to system | ● | ● | ● | ● | ● | ● | ● |
| 1.3.22 | Program provides User Tracking (Audit log) e.g. who accessed the record and when | ● | ● | ● | ● | ● | ● | ● |
| 1.3.23 | Provide flexible password control to align with national policy and standard operating procedures | ● | ● | ● | ● | ● | ○ | ● |
| 1.3.24 | Restrict user password revisions and force users to change their passwords at determined intervals | ● | ● | ● | ● | ● | ○ | ● |
| 1.3.25 | Log-in restrictions - Terminate user log-in screen after determined number of unsuccessful attempts to log in | ● | ● | ● | ● | ● | ○ | ● |
| 1.3.26 | Timeout restrictions- Automatically log off idle workstations after predetermined time period | ● | ● | ● | ● | ● | ○ | ● |
| 1.3.27 | Create rights and privilege groups by type of user | ● | ● | ● | ● | ● | ● | ● |
| 1.3.28 | Create unique user rights based on functions and screen displays | ● | ● | ● | ● | ● | ● | ● |
| 1.3.29 | Store data centrally in a physically secure location | ● | ● | ● | ● | ● | ● | ● |
| 1.3.30 | Store data centrally using cloud computing software | ● | ● | ○ | ● | ● | ○ | ● |

| 1.3 | Requirements Comparability Matrix – Technical Design | HealthSIS | EpiAnywhere | MAVEN | Trisano | WorldCare | NBS | Sentinel |
|--------|--|-----------|-------------|-------|---------|-----------|-----|----------|
| | | | | | | | | |
| | User Interface | | | | | | | |
| 1.3.31 | Intuitive UI that is easy to use | ● | ● | ● | ● | ● | ● | ● |
| 1.3.32 | Consistent and well-defined interface | ● | ● | ● | ● | ● | ● | ● |
| 1.3.33 | Supports Browser based UI (i.e. IE, Firefox, Safari, etc) | ● | ● | ● | ● | ● | ● | ● |
| 1.3.34 | Search functionality to easily find data in any/multiple field(s) and retrieve matches | ● | ● | ● | ● | ● | ○ | ● |
| 1.3.35 | Ability to configure users interface per user | ○ | ○ | ● | ○ | ● | ● | ○ |
| 1.3.36 | Ability to configure users interface globally | ● | ● | ● | ● | ● | ● | ● |
| 1.3.37 | Supports multiple monitor resolutions | ● | ● | ● | ● | ● | ● | ● |
| 1.3.38 | Consistent GUI (e.g., windows, icons, mouse, pull-down menus) and effective use of color | ● | ● | ● | ● | ● | ● | ● |
| 1.3.39 | Support internationalization- Supports international use | ● | ● | ● | ● | ● | ○ | ● |
| 1.3.40 | User interface is customizable allows for corporate branding | ● | ● | ● | ● | ● | ● | ● |
| 1.3.41 | Section 508 Compliant | ● | ● | ● | ● | ● | ● | ● |
| 1.3.42 | Dashboard capability | ● | ● | ● | ● | ● | ● | ● |
| 1.3.43 | Ability to easily navigate between screens | ● | ● | ● | ● | ● | ● | ● |
| 1.3.44 | Action buttons (Search, Back, Save, Next, Delete, etc...) | ● | ● | ● | ● | ● | ● | ● |
| 1.3.45 | Displays screen headers with user information or other user-defined information | ● | ● | ● | ● | ● | ● | ● |
| 1.3.46 | Displays screen labels/headers | ● | ● | ● | ● | ● | ● | ● |

| 1.3 | Requirements Comparability Matrix – Technical Design | HealthSIS | EpiAnywhere | MAVEN | TriSano | WorldCare | NBS | Sentinel |
|---|---|-----------|-------------|-------|---------|-----------|-----|----------|
| Legend: ● Fully Meets Requirement ● Partially Meets Requirement ○ Does Not Meet Requirement | | | | | | | | |
| User Interface (cont'd) | | | | | | | | |
| 1.3.47 | Help text configuration ability to provide field description and definition | ● | ● | ● | ● | ● | ● | ● |

1.4 Data Exchange and Integration

| 1.4 | Requirements Comparability Matrix – Data Exchange & Integration | HealthSIS | EpiAnywhere | MAVEN | TriSano | WorldCare | NBS | Sentinel |
|---|--|-----------|-------------|-------|---------|-----------|-----|----------|
| Legend: ● Fully Meets Requirement ● Partially Meets Requirement ○ Does Not Meet Requirement | | | | | | | | |
| Data Exchange and Integration | | | | | | | | |
| 1.4.1 | Allows for interoperability with other designated systems (including systems outside of public health e.g. lab systems, state systems, etc.) | ● | ○ | ● | ● | ● | ● | ● |
| 1.4.2 | Program provides an API | ○ | ○ | ○ | ● | ● | ○ | ○ |
| 1.4.3 | Compliant with Health Level Seven (HL7) data exchange standards | ● | ● | ● | ● | ● | ● | ● |
| 1.4.4 | Allow for a protocol definition for case acceptance/transfer from other public health jurisdictions | ○ | ○ | ● | ● | ● | ● | ● |
| 1.4.5 | Allow automatic processing of scheduled batched jobs based on user-defined triggers (hourly, daily, weekly, etc.) | ○ | ● | ● | ● | ● | ● | ● |
| 1.4.6 | Report data stream/ job failures | ● | ○ | ● | ● | ● | ● | ○ |

| 1.4 | Requirements Comparability Matrix – Data Exchange & Integration Legend: ● Fully Meets Requirement ● Partially Meets Requirement ○ Does Not Meet Requirement | HealthSIS | EpiAnywhere | MAVEN | Trisano | WorldCare | NBS | Sentinel |
|---|---|-----------|-------------|-------|---------|-----------|-----|----------|
| Data Exchange and Integration (cont'd) | | | | | | | | |
| 1.4.7 | Perform regular data processing procedures | ● | ● | ● | ● | ● | ● | ● |
| 1.4.8 | Have the ability to notify "sharing agency" of data changes in the system | ○ | ○ | ● | ● | ● | ● | ○ |
| 1.4.9 | Support merging and standardizing data into a uniform format | ○ | ○ | ● | ● | ● | ● | ● |
| 1.4.10 | Have the ability to perform data quality checks | ● | ● | ● | ● | ● | ● | ● |
| 1.4.11 | Support de-identification of patient data | ○ | ○ | ● | ● | ● | ● | ● |
| 1.4.12 | Allow sharing agency to specify sharing rules | ● | ○ | ● | ○ | ○ | ● | ○ |
| 1.4.13 | Have ability to implement jurisdictional/geographically-based rules | ● | ● | ● | ● | ● | ● | ● |
| 1.4.14 | Allow user to set up and modify rules to provide differential views for "receiving agency" | ● | ● | ● | ● | ● | ● | ● |
| 1.4.15 | Utilize privacy- and security-based rules | ● | ● | ● | ● | ● | ● | ● |
| 1.4.16 | Have the ability to notify appropriate "receiving agency" of available data | ○ | ○ | ● | ○ | ● | ● | ○ |
| 1.4.17 | Support versioning and saving of data and metadata | ● | ● | ● | ● | ● | ● | ● |
| 1.4.18 | Allow "receiving agency" to view, import, or retrieve/receive allowable data in designated format | ● | ● | ● | ● | ● | ● | ● |
| 1.4.19 | Allow "receiving agency" to identify data that are new or updated | ○ | ○ | ● | ○ | ● | ● | ○ |
| 1.4.20 | Support automatic system-to-system transmission of data | ● | ● | ● | ● | ● | ○ | ● |
| 1.4.21 | Support notification alerts to receiving system | ○ | ○ | ● | ○ | ● | ○ | ○ |
| 1.4.22 | Support versioning of rules and data | ● | ● | ● | ● | ● | ● | ● |

| 1.4 | Requirements Comparability Matrix – Data Exchange & Integration | HealthSIS | EpiAnywhere | MAVEN | TriSano | WorldCare | NBS | Sentinel |
|---|--|-----------|-------------|-------|---------|-----------|-----|----------|
| Legend: ● Fully Meets Requirement ● Partially Meets Requirement ○ Does Not Meet Requirement | | | | | | | | |
| Data Exchange and Integration (cont'd) | | | | | | | | |
| 1.4.23 | Allow receiving agency the ability to retrieve data for information shared by sharing agency | ● | ● | ● | ● | ● | ● | ● |
| 1.4.24 | Log date and timestamp when data are made available to "receiving agency" | ● | ● | ● | ● | ● | ● | ● |
| 1.4.25 | Have the ability to identify user who made the data available to "receiving agency" | ● | ● | ● | ● | ● | ● | ● |
| 1.4.26 | Allow "receiving agency" to alert "sharing agency" of receipt /non receipt of data or problem(s) with data | ○ | ○ | ● | ○ | ● | ● | ○ |
| 1.4.27 | Support electronic or manual logging of data-sharing errors | ○ | ○ | ● | ○ | ● | ● | ○ |

1.5 Data Analysis, Visualization and Reporting

| 1.5 | Requirements Comparability Matrix – Data Analysis, Visualization and Reporting | HealthSIS | EpiAnywhere | MAVEN | TriSano | WorldCare | NBS | Sentinel |
|---|--|-----------|-------------|-------|---------|-----------|-----|----------|
| Legend: ● Fully Meets Requirement ● Partially Meets Requirement ○ Does Not Meet Requirement | | | | | | | | |
| Data Analysis, Visualization and Reporting | | | | | | | | |
| 1.5.1 | Available canned reports (workflow, surveillance) | ● | ● | ● | ● | ● | ● | ● |
| 1.5.2 | Uses custom reporting technology (Ad Hoc Reporting) | ● | ● | ● | ● | ● | ● | ● |

| 1.5 | Requirements Comparability Matrix – Data Analysis, Visualization and Reporting Legend: ● Fully Meets Requirement ● Partially Meets Requirement ○ Does Not Meet Requirement | HealthSIS | EpiAnywhere | MAVEN | Trisano | WorldCare | NBS | Sentinel |
|--|--|-----------|-------------|-------|---------|-----------|-----|----------|
| Data Analysis, Visualization and Reporting (cont'd) | | | | | | | | |
| 1.5.3 | Program supports Electronic Laboratory Reporting (ELR) | ● | ○ | ● | ● | ● | ● | ● |
| 1.5.4 | Allow user to select multiple variables for analysis | ● | ● | ● | ● | ● | ● | ● |
| 1.5.5 | Allow for predefined parameters | ● | ○ | ● | ● | ● | ● | ● |
| 1.5.6 | Support robust search logic capability | ○ | ● | ● | ● | ● | ○ | ● |
| 1.5.7 | Allow user to select and save parameters for future use | ● | ● | ● | ● | ● | ● | ● |
| 1.5.8 | Allow user to view all available parameters | ● | ● | ● | ● | ● | ● | ● |
| 1.5.9 | Allow user to view definition of predefined variables | ● | ● | ● | ● | ● | ● | ● |
| 1.5.10 | Allow user to set filters and defaults for each variable | ● | ● | ● | ● | ● | ● | ● |
| 1.5.11 | Date/time-stamp when data are pulled in and saved | ● | ● | ● | ● | ● | ● | ● |
| 1.5.12 | Allow user to convert one-time queries to routine queries | ● | ● | ● | ● | ● | ● | ● |
| 1.5.13 | Allow recurring scheduling of queries/reports and option to push to distribution list of recipients | ○ | ● | ● | ● | ● | ● | ● |
| 1.5.14 | Allow user to create selected charts, graphs and GIS maps | ● | ● | ● | ● | ● | ● | ● |
| 1.5.15 | Allow user to isolate a subset of data on the chart or graph for further analysis | ● | ● | ● | ● | ● | ○ | ● |
| 1.5.16 | Allow user to select a predefined statistical analysis method | ○ | ○ | ● | ● | ● | ○ | ● |
| 1.5.17 | Allow user to export data | ● | ● | ● | ● | ● | ● | ● |
| 1.5.18 | Allow user to view estimated time required to wait before requested data are displayed | ○ | ○ | ○ | ○ | ○ | ○ | ○ |

| 1.5 | Requirements Comparability Matrix – Data Analysis, Visualization and Reporting Legend: ● Fully Meets Requirement ● Partially Meets Requirement ○ Does Not Meet Requirement | HealthSIS | EpiAnywhere | MAVEN | Trisano | WorldCare | NBS | Sentinel |
|--|--|-----------|-------------|-------|---------|-----------|-----|----------|
| Data Analysis, Visualization and Reporting (cont'd) | | | | | | | | |
| 1.5.19 | Allow user to apply filters to data returned from query/filters | ● | ● | ● | ● | ● | ● | ● |
| 1.5.20 | Allow user to customize report templates | ● | ○ | ● | ● | ● | ● | ● |
| 1.5.21 | Allow user to predefine report templates | ● | ○ | ● | ● | ● | ● | ● |
| 1.5.22 | Allow user to select a predefined report template | ● | ● | ● | ● | ● | ● | ● |
| 1.5.23 | Allow user to create customized maps and graphs | ● | ○ | ● | ● | ● | ● | ● |
| 1.5.24 | Allow user to apply filters to map and underlying data | ● | ○ | ● | ● | ● | ○ | ● |
| 1.5.25 | Allow user to perform various statistical analyses on dataset | ● | ● | ● | ● | ● | ● | ● |
| 1.5.26 | Allow scheduling of recurring reports and option to push to distribution list of recipients | ● | ○ | ● | ● | ● | ● | ● |
| 1.5.27 | Allow user to design and save report template | ● | ○ | ● | ● | ● | ● | ● |
| 1.5.28 | Allow user to archive final reports | ● | ● | ● | ● | ● | ● | ● |
| 1.5.29 | Data Quality Assurance /Quality Control reporting functionality (report of validation errors) | ● | ● | ● | ● | ● | ● | ● |

Appendix B: Glossary

algorithms

a process or set of rules to be followed in calculations or other problem-solving operations, especially by a computer

audit trail

a security-relevant chronological record, set of records, or destination and source of records that provide documentary evidence of the sequence of activities that have affected at any time a specific operation, procedure, or event

browser

a program used to view websites (called a web browser); serves as the portal for most EDSS

cloud-based

used to describe a service housed on the internet, where normally it would be housed on location on a physical device

customization

customization of the system is fundamentally changing the code to better suit your needs

configuration

configuration of the system is unlocking all the capabilities of the software to better suit your needs

de-duplicate

prevent two of the same data points to be in the system, i.e. only keep one of two individuals with matching standard information

defect

a “bug” in the code which causes the software to act in an unanticipated way

deployment

the act of installing and turning on a software package

end user

people who use the system

interoperability

ability of diverse systems and organizations to work together

open source

software for which the source code is freely available, allowing anyone to add on to the code

patches

code releases meant to fix a group of defects. Usually scheduled on an as needed basis

real time

occurring now with no discernible delay

releases

software updates which are usually rolled out on a published scheduled basis

semantically

data are validated against specific business rules (i.e. a diagnosis date could not occur before a birth date)

syntactically

data are validated against the field or form type (i.e. a name could not be entered in a field that requires a date)

template

something that serves as a model. In the case of software systems, this could be forms or structures that could be re-used and not need to be created from scratch

user role

the specific role given the user in the system. This role defines what the user can access in the system

user interface

the user interface is what the end user interacts with to use the system

Appendix C: CSTE List of Nationally Notifiable Conditions 8/1/2012

1. Anaplasmosis
2. Anthrax
3. Arboviral disease (Calif. serogroup, EEE, Powassan, SLE, WNV, WEE)
4. Babesiosis
5. Botulism
6. Brucellosis
7. Cancer
8. Chancroid
9. Chlamydia trachomatis infection
10. Coccidioidomycosis
11. Cryptosporidiosis
12. Cyclosporiasis
13. Dengue virus infections
14. Diphtheria
15. Ehrlichiosis
16. Escherichia coli , Shiga toxin-producing (STEC)
17. Foodborne disease outbreaks
18. Giardiasis
19. Gonorrhea
20. Haemophilus influenzae, invasive disease
21. Hansen's disease
22. Hantavirus pulmonary syndrome
23. Hemolytic uremic syndrome, post-diarrheal
24. Hepatitis A, acute
25. Hepatitis B, acute
26. Hepatitis B, chronic
27. Hepatitis B, perinatal infection
28. Hepatitis C infection, past or present
29. Hepatitis C, acute
30. HIV Infection
31. Influenza-associated mortality, pediatric
32. Lead, exposure screening test result
33. Legionellosis
34. Leptospirosis
35. Listeriosis
36. Lyme disease
37. Malaria
38. Measles
39. Meningococcal disease (Neisseria meningitidis)
40. Mumps
41. Novel influenza A virus infection, initial detections of Measles
42. Paralytic poliomyelitis
43. Pertussis
44. Pesticide-related illness, acute
45. Plague
46. Poliovirus infection, nonparalytic
47. Psittacosis
48. Q Fever
49. Rabies in a human
50. Rabies in an animal
51. Rickettsiosis, Spotted Fever
52. Rubella
53. Rubella, congenital syndrome
54. Salmonellosis
55. SARS - associated coronavirus
56. Shigellosis
57. Silicosis
58. Smallpox
59. Staphylococcus aureus infection - Vancomycin-intermediate (VISA), Vancomycin-resistant (VRSA)
60. Streptococcal toxic shock syndrome (STSS)
61. Streptococcus pneumoniae , invasive disease (IPD)
62. Syphilis
63. Tetanus
64. Toxic shock syndrome (non-Strep)
65. Trichinellosis (Trichinosis)
66. Tuberculosis
67. Tularemia
68. Typhoid Fever
69. Varicella
70. Vibrio cholerae infection (Cholera)
71. Vibriosis
72. Viral Hemorrhagic Fevers
73. Waterborne disease outbreaks
74. Yellow Fever

Appendix D: Information Gathering Process

Information Gathering Process

Electronic Disease Surveillance System Analysis

1 of 2

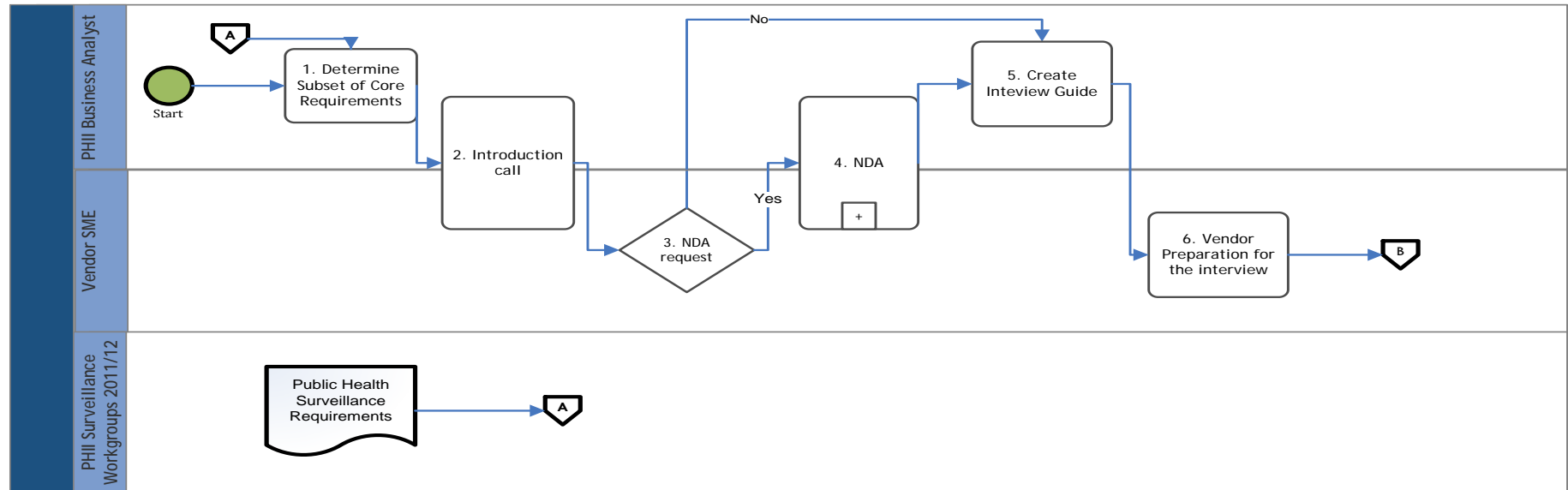

| | | | | |
|------------------------------|---|--|---|---|
| Activity Details / Narrative | <p>General Process Notes</p> <p>Objective:</p> <ul style="list-style-type: none"> Provide a flow for how the information is gathered in order to inform the analysis of the vendors <p>Measurable Outcomes:</p> <ul style="list-style-type: none"> Vendor information is received and compiled for the vendor analysis within the project's timeline | <p>General Process Notes</p> <p>Between October 2011 and March 2012, the Public Health Informatics Institute applied its Collaborative Requirements Development Methodology (CRDM) to facilitate three workgroup sessions that consisted of 10 public health surveillance practitioners from different states and locales. The workgroup collaboratively defined and developed functional requirements for an Electronic Disease Surveillance System (EDSS). The requirements developed in the workgroup were used to assess the software applications selected for the EDSS vendor analysis.</p> | <p>Activity Description:</p> <ol style="list-style-type: none"> Determine subset of core requirements <ul style="list-style-type: none"> Reduction of initial documentation of requirements Conduct introduction call <ul style="list-style-type: none"> Identify contacts and make introduction This call is used to schedule the rest of the interactions as well Request for a Nondisclosure Agreement <ul style="list-style-type: none"> This is an "if necessary" step, as expressed by the vendors Complete Nondisclosure Agreement <ul style="list-style-type: none"> NDA is decided between PHII and the Vendor All parties must sign the NDA (PHII, Vendor, North Highland) | <ol style="list-style-type: none"> Create the Interview Guide <ul style="list-style-type: none"> Serves as prep and agenda for the Vendor Interviews Vendor preparation for the interview <ul style="list-style-type: none"> Uses the Interview Guide |
|------------------------------|---|--|---|---|

Information Gathering Process

Electronic Disease Surveillance System Analysis

2 of 2

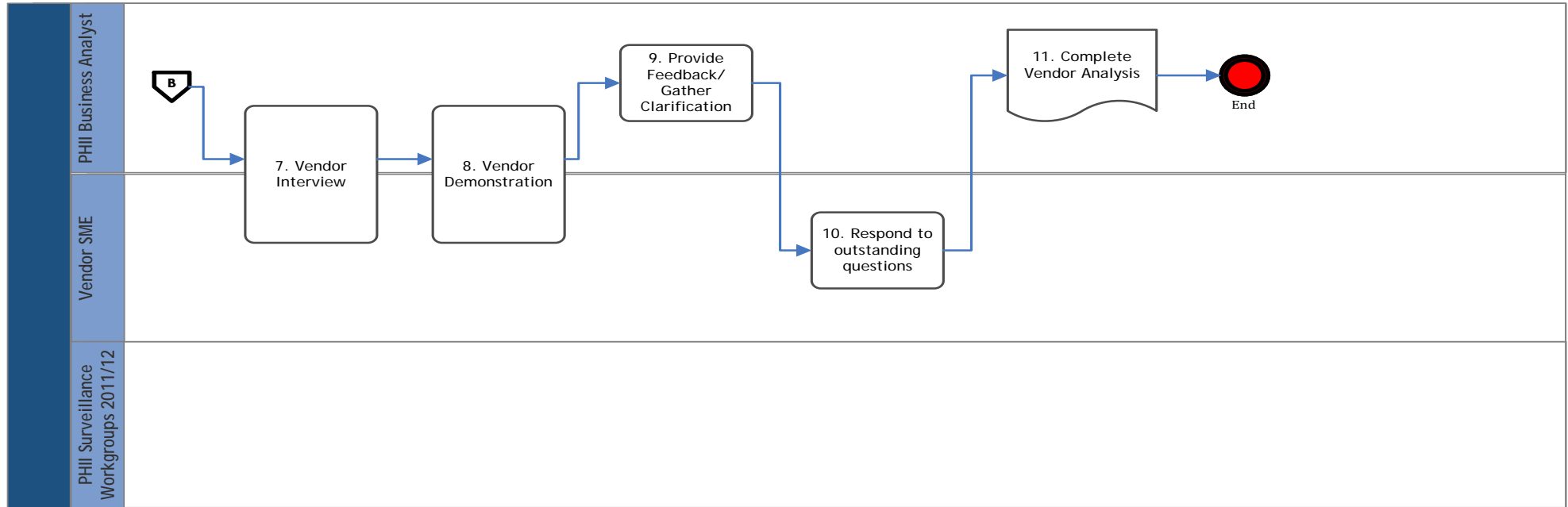

| | | | | |
|------------------------------|--|--|--|--|
| Activity Details / Narrative | <p>General Process Notes</p> <p>Objective:</p> <ul style="list-style-type: none"> Provide a flow for how the information is gathered in order to inform the analysis of the vendors <p>Measurable Outcomes:</p> <p>Vendor information is received and compiled for the vendor analysis within the project's timeline</p> | <p>General Process Notes</p> <p>Between October 2011 and March 2012, the Public Health Informatics Institute applied its Collaborative Requirements Development Methodology (CRDM) to facilitate three workgroup sessions that consisted of 10 public health surveillance practitioners from different states and locales. The workgroup collaboratively defined and developed functional requirements for an Electronic Disease Surveillance System (EDSS). The requirements developed in the workgroup were used to assess the software applications selected for the EDSS vendor analysis.</p> | <p>Activity Description:</p> <p>7. Vendor Interview</p> <ul style="list-style-type: none"> Conducted using the interview guide Scheduled for an hour and a half <p>8. Vendor Demonstration</p> <ul style="list-style-type: none"> A script is provided as a "guideline" for the hour long vendor demonstration <p>9. Provide feedback/gain clarification</p> <ul style="list-style-type: none"> Provide the vendor feedback on requirements which were deemed "not met" Get clarification on any outstanding questions or possible points of contention <p>10. Respond to outstanding questions</p> <ul style="list-style-type: none"> The vendor answer to the previous activity | <p>11. Complete Vendor Analysis</p> <ul style="list-style-type: none"> Fill out the requirements guide based on the information gathered |
| | | | | |

Appendix E: Interview Guide

Interview Objectives

- Understand the software and how it addresses the requirements for the assessment
- Determine functionality and other profile information of the software and vendor.
- Determine next steps in acquiring information for the assessment.

Introduction

As a reminder, this interview will be taped so that I can gather the notes from recording at a later time.

Thank you for making the time to participate in this interview. As previously mentioned, we will be interviewing you to help determine how **[EDSS Vendor]** meets the requirements for Electronic Disease Surveillance Systems. We'll start by asking questions specifically around the Reportable Conditions modules and then move on to more general system questions and requirements.

Questions

1. Reportable Conditions Surveillance Core Modules

- Please list the reportable diseases/conditions supported by the system.
- Does the system concentrate on certain diseases/conditions?
- Can new conditions/diseases be added? If so, how are they added and how complex is the undertaking?

Describe the highlights of how the system implements **Condition Identification and Reporting**.

- Can users configure filter parameters (based on jurisdictional rules)?
- Communications functionality? (Automation of, notifications to sender on receipt of report, etc.)
- Are records flagged to indicate when lab results have been received?
- Does the system support specific laboratory testing requirements for each condition?
- Does the system support multiple lab formats? How many, which type?(test performed, quantity, quality, how stored and how long stored)

Describe the highlights of how the system implements **Event Identification and Validation**.

- How (and in what type of formats) does the system receive lab messages? Can formats be adjusted?
- Can the user utilize geographical/temporal data to identify events? Are algorithms used and how?
- Does the system maintain directories of searchable data sources, organized by jurisdictional area?
- Can it recognize event trends?
- Can data: be grouped? Using Pre-defined Criteria? By Syndromes? Across different sources? Re-categorized or regrouped with the introduction of new data?
- Is there case routing to respective program areas within the system?
- Are there user-defined priority thresholds that can be outlined in definitions?
- Is there a workflow around the event? (triage, route referrals for investigation, etc.)?

How does the system support **Case Investigation**?

- Can you assign a case to an investigator? Is there a transaction log around the assignment?
Can you create a case off of a contact record?
- Are there case Templates? Do users have the ability to save and design forms? Do users have the ability to save and design questionnaires?
- Cases:
 - Accept/Reject/Save
 - Signoff Definitions
 - Send and receive forms from/to Care Providers
 - Multiple input methods (manual, scanning, optical reader, etc.)
 - Attachments
 - Standard demographic information
 - Legal responsibility (parent, guardian)
- Does the software allow algorithm to perform risk evaluation prioritization?
- Can users assign and override a priority based on an evaluation?
- Does the system support contact tracing?
- Can the system evaluate criteria to determine demographic information? (relations)
- Tracking:
 - Multiple instances of locators (geographic, telephone)
 - Like identifiers (driver's license, patient ID)
 - Multiple lab reports for an individual case (keeping source information)
 - Multiple results for a sign or symptom
 - Source of exposure
- Does the system auto-classify? Does it automatically suggest and update classifications as well?

How does the system support **Contact Tracing**?

- Can the system link one uniquely defined person to another?
- Does contact tracing have a visual representation?
- In addition to standard profile data, can the system:
 - Capture risk factor data
 - Categorize contacts by some type of user defined characteristics
 - Sort contact list by user defined characteristics
 - Capture contact info for the facility vs. the individual (for aggregate investigations)
 - Provide Free form text box for info/notes
 - Manage or track interview status
- Does it allow association of contact with an index case?
- Does it provide the ability to prioritize contact follow-up?

How does the system support **Case/Contact Specific Intervention**?

- Intervention Plans:
 - Does it allow a user to select predefined plans?
 - Display those plans, including suggesting a plan?
 - Modify the plans?
 - Add it to an existing case record?
 - Create/edit/save plans?
- Does the system provide workflow capability around the case? (Adding, closing, saving, linking to an index case, notifications based on incubation, etc.)
- Does the system have automated clean up functionality? (i.e. case is old, etc.)

How does the system support **Event/Outbreak Management**?

- What types of communication are available? In conjunction, what methods are available to collect feedback on the communications?
- Are historical outbreaks case definitions kept in the system? If so, how long are they kept? Are they searchable?
- Outbreak plans:
 - Save, Generate, Edit
 - Template library
 - Assign definitions based on jurisdiction, then be able to identify new cases
- Can the user document an outbreak or event management plan?
- Can cases be linked to outbreaks/events?
- Tracking:
 - Number of cases (confirmed/probable)
 - By geography/setting
 - All other demographic information
 - Temporal and spatial clustering of cases
 - Link test results and additional info
 - Link case/contact specific intervention record
 - Link questionnaires to case investigation
 - Maintain multiple disease/condition/outbreak-specific classification criteria
 - Classify contacts based on location/risk factors
 - Link contacts with index case
 - Interview status and follow ups
- Monitoring:
 - Data streams on user defined criteria (syndromic data, diagnostic testing, absenteeism, OTC medication sales, etc.)
 - Type and number of tests ordered by care providers
 - Chief complaints
 - OTC purchases
 - Emergency Department Admissions
 - Newly identified sources of data
 - In real-time
 - Determine if contact meets exposure criteria
 - Set/Modify exposure criteria
- Metrics:
 - Create/Define
 - Edit/Save
 - Update Epidemiologic curves
 - Summary statistics of key variables, including completeness, frequencies and means
 - Allow for importing formulas or defining new thresholds (user programmed analytics)
 - Supports calculations of epidemiologic stats
- Reporting:
 - Alerts on outstanding tasks in the outbreak management plan
 - Media templates (Create/Edit/Save)
 - After action reports
 - Track communication outcome and measures for reporting/refining activities
 - Case classification in condition identification, based on outbreak definition
 - Customized/Ad-hoc Reporting

- Sending/Receiving Reports
- GIS, Graphs, etc.
- Records:
 - Create/Edit/Save/Log Creator
 - Unique Record Number

How does the system support **Public Health Alerts**?

- Communications:
 - Public alert networks
 - Social networks
 - Allows users to create/edit/send messages
 - HAN interface
 - Two way communication between “sharing” agency and “receiving” agency

2. Integration

- What types of systems does the program integrate with? (ELR, EHR, lab systems, general public health systems)
- What specific systems does the program integrate with?
- How does the system integrate with other systems? (interfaces, import/export, API, real-time)
- Is there “data-sharing” between systems, and if so what are the specifics around the timing? (real-time, daily/weekly/monthly jobs)
- Describe the system’s approach / strategy for integration to third party applications.

3. System Architecture

- Describe (in detail) the system’s architecture including hardware, OS, database, and development platforms (provide diagrams where possible.)
- Describe the system’s approach / strategy for configuration as well as any specific configuration options.
- Describe your approach for future system releases including relevant migration strategies. (Include any considerations for current or future cloud-based solutions/releases.)
- Describe the SDLC of the system, specifically around releases, fixes, notes, etc.
- Describe the archiving process, if any. How often? How long are data kept?

4. Data Security

- Describe the system’s approach / strategy for user-level access control.
- Describe the system’s data security approach.

5. Customer Support

- Describe (in summary) your company’s customer / end-user system support options.
- Describe (in summary) your company’s maintenance agreement including all support services.
- Describe your company’s deployment (or other value added) support services.

6. User Requirements

- How can the system be accessed? (web, mobile, portal, etc.)
- For imports/exports, in what ways can data move in to/out of the system? (manual, interface, scanner, fax, etc.)
- Describe the steps you’ve taken in designing the User Interface.

- Describe how data validation is handled in the system, both manual entry and imported data. Please include whether versioning of the data occurs.
- Describe the ability to provide data in dashboards, if applicable. Please include the types of dashboards to be displayed and the customization/configuration aspect of them.

7. Total Cost of Ownership

- Describe (in summary) your company's end-user licensing agreement.
- Describe (in summary) any/all ongoing costs (including maintenance) associated with system licensing.

8. Differentiation

- What would you describe as the most innovative features of your system?
- What features do you feel most differentiate your system from the EDSS marketplace at large?
- How many installations are currently being operated within the US public health community?

Appendix F: Demonstration Script

Vendor Demonstration Overview

This demonstration script was created so that each software vendor would be performing the same activities within their respective systems, in order to add uniformity to the system demonstration portion of the information gathering process. As such, we are focusing on the core requirements for a public health end user to be able to successfully use the EDSS to execute their job responsibilities. Since different systems have different target functionality, only those functions that are implemented in a given system will be applicable to the demonstration. In addition, for the “unscripted” part of the demonstration, we ask that the vendors give a general walkthrough or “sales demo”, highlighting any innovative or differentiating functionality in their system. We’ve allotted 30 minutes to go through the standard activities of an EDSS and another 30 minutes for free-form demonstration. We ask that the session be interactive so that we can ask questions and receive clarification.

Attendees

Mandatory
(Optional)

Scripted Session: 30 Minutes

1. System Access

- Launch Electronic Disease Surveillance System
- Show and/or describe sign-on procedure to EDSS

2. Condition Identification and Reporting (if applicable)

- Show how to manually create a condition identification. (If possible, create one for an STD, and one for a type of cancer.)
- Show how the system accepts a condition report from a third party. Please include any communications around receiving of the information.
- Show any workflow/audit steps for either steps 1 or 2.

3. Event Identification and Validation (if applicable)

- Show how a user can utilize geographical or temporal data to identify an event.
- Show how a user can identify an event.
- Show how the system recognizes event trends.
- Show workflow/audit log around the event. Demonstrate triage and routing referrals for investigation.

4. Case Investigation (if applicable)

- Create a case from an existing template.
- Assign a case to an investigator.
- Show where attachments/notes/etc. are stored with the case.
- Show how the system auto-classifies the case.
- Override the priority of the case based on an evaluation.

5. Contact Tracing (if applicable)

- Link a uniquely defined person to another uniquely defined person.
- Show a visual representation of the contact tracing.
- Show the ability to add various pieces of data including risk factor/categorization/facility contact information.

- Associate the contact with an index case.
- 6. Case/Contact Specific Intervention (if applicable)**
 - Choose a pre-defined intervention plan.
 - Edit the plan and save the plan.
 - Walkthrough the plan workflow for the newly created plan.
 - 7. Event/Outbreak Management (if applicable)**
 - Open an outbreak plan from a template.
 - Link multiple cases to the event or outbreak.
 - Link a contact to an event or outbreak.
 - 8. Public Health Alerts (if applicable)**
 - Show how the system communicates with third party public health systems.
 - 9. Monitoring and Reporting (if applicable)**
 - Demonstrate the ability to view data in a real time environment. (Dashboards)
 - Demonstrate the ability to create an Ad-hoc report.
 - Demonstrate the graphical visualization of data in the system.

Unscripted Session: 30 minutes

Please give a brief overview of what you plan on showing during the unscripted portion of the demonstration. Again, this session should center around an overall system demonstration, as well as showing what is innovative or differentiating about your system. This should give us a good feel for how the system operates.

Appendix G: RFP Template

Request for Proposal

Preparing a Request for Proposal (RFP)

Preparing a Request for Proposal can be a challenging process. It is important that you properly prepare and allow sufficient time to fully understand your business requirements and your procurement policies, and to thoroughly evaluate potential software vendors. Typically, it takes from six to twelve months to complete the RFP process, depending on the complexity of the information system.

The RFP begins with understanding your business requirements and categorizing them as “need to have” versus “nice to have”. There may be additional technical requirements or constraints that must be articulated to the vendors, so it is best to involve your IT department early in this process.

You may already have an RFP/RFQ template which you may be required to use as the basis for your solicitation. Numerous regulations are likely to govern the sequence, timing, publication and communications requirements of your competitive solicitation. Be sure to connect with your procurement, legal and other departments early to understand these requirements.

Vendor Selection

Be sure to allow enough time for respondents to prepare thorough responses to the RFP. Responses will then be evaluated and ranked on the basis of how closely they align with your “need to have” and technical requirements, with consideration given to “nice to have” as a further ranking criteria. Based on this evaluation, you may select one or more respondents to perform live demonstrations of their systems, incorporating several use cases that you will provide ahead of time. Depending on the breadth of the functionality, it will be best to allot half- or full-day sessions for these use-case demonstrations.

The value of your RFP and the resulting demonstrations in making the best vendor selection will depend on the clarity and applicability of the use cases you define, and on determining prior to the demonstration how – based on what criteria – the use-case demonstrations will be judged. Take time immediately following each presentation to evaluate the strengths, weaknesses and/or scores for each use case, based on the judgment criteria previously established.

In addition to evaluating the ability of the vendor to address your specific business and technical requirements, several additional factors should be considered. It will be important to understand the overall cost of owning the software, including start-up and maintenance costs, and to ascertain the vendor’s customer service capability, both their track record of customer satisfaction, as well as their strategy for maintaining and upgrading their software. Along these lines, it is equally important to assess the vendor’s financial viability. It would be unfortunate indeed to purchase software with all of the correct functionality from a vendor on the verge of bankruptcy, which could leave you with no one to turn to for support or maintenance of your software.

Although the RFP and vendor selection process requires significant effort and due diligence, the result will be a well-organized and documented approach that allows you to select the most appropriate software application and vendor to meet your business needs.

RFP Table of Contents

Project Overview

- Provide a brief high-level description of the organization, purpose of the project and what you plan to achieve by implementing the new information system. Typically 1 – 2 pages in length.

Project Background and Goals

- Provide details on how and why the project was conceived and the specific goals that the project has set out to accomplish. Typically 1 – 2 pages in length.

Scope of Project

- Describe the details of the scope of the project. It is also helpful to provide insight to what is defined as out-of-scope. The more clarity provided here, the better the vendor can assess their ability to meet your needs. Typically 1 – 3 pages in length.

Project Deliverables

- Describe the specific project deliverables that the vendor will be responsible for completing as part of this project. This section typically details expectations related to implementing the information system, user testing, system documentation, system maintenance, and technical support.

Evaluation Selection Criteria

- Describe in detail the criteria, along with weighting factors that will be used to evaluate the vendor. This is typically laid out in a matrix or table structure, along with a scoring scheme. More weight is given to those areas of highest importance.

Attachments

Requirements

General System Assessment

Vendor Assessment